

# User Guide

## FM-750™ Display

**Version 4.0**  
Revision A  
April 2013

# Legal Notices

## Agriculture Business Area

Trimble Navigation Limited  
Trimble Agriculture Division  
10355 Westmoor Drive  
Suite #100  
Westminster, CO 80021  
USA

[trimble\\_support@trimble.com](mailto:trimble_support@trimble.com)  
[www.trimble.com](http://www.trimble.com)

## Copyright and Trademarks

© 2010-2013, Trimble Navigation Limited. All rights reserved.

Trimble, the Globe & Triangle logo, AgGPS, EZ-Guide, EZ-Steer, T2, and Tru Count Air Clutch are trademarks of Trimble Navigation Limited, registered in the United States and in other countries.

Autopilot, Center Point, CFX-750, CenterPoint, Connected Farm, EZ-Pilot, Field-IQ, FM-750, FreeForm, RangePoint, RTX, T3, Tru Count LiquiBlock, VRS, and xFill are trademarks of Trimble Navigation Limited.

For STL support, the software uses the Moscow Center for SPARC Technology adaptation of the SGI Standard Template Library. Copyright © 1994 Hewlett-Packard Company, Copyright © 1996, 97 Silicon Graphics Computer Systems, Inc., Copyright © 1997 Moscow Center for SPARC Technology.

Microsoft, Windows, ActiveX, Excel, and Internet Explorer are either registered trademarks or trademarks of Microsoft Corporation in the United States and/or other countries.

Portions Copyright © 2009 Nokia Corporation and/or its subsidiary(-ies).

Portions Copyright © 2003, Bitstream Inc.

All other trademarks are the property of their respective owners.

## Release Notice

This is the April 2013 release (Revision A) of the FM-750 Display User Guide. It applies to version 4.0 of the FM-750 display software.

## Legal Notices

The following limited warranties give you specific legal rights. You may have others, which vary from state/jurisdiction to state/jurisdiction.

## Product Limited Warranty

Trimble warrants that this Trimble product and its internal components (the "Product") shall be free from defects in materials and workmanship and will substantially conform to Trimble's applicable published specifications for the Product for a period of two (2) years, starting from the earlier of (i) the date of installation, or (ii) six (6) months from the date of original Product shipment from Trimble. This warranty applies only to the Product if installed by Trimble or a dealer authorized by Trimble to perform Product installation services.

## Software Components

All Product software components (sometimes hereinafter also referred to as "Software") are licensed solely for use as an integral part of the Product and are not sold. Any software accompanied by a separate end user license agreement ("EULA") shall be governed by the terms, conditions, restrictions and limited warranty terms of such EULA notwithstanding the preceding paragraph.

During the limited warranty period you will be entitled to receive such Fixes to the Product software that Trimble releases and makes commercially available and for which it does not charge separately, subject to the procedures for delivery to purchasers of Trimble products generally. If you have purchased the Product from an authorized Trimble dealer rather than from Trimble directly, Trimble may, at its option, forward the software Fix to the

Trimble dealer for final distribution to you. Minor Updates, Major Upgrades, new products, or substantially new software releases, as identified by Trimble, are expressly excluded from this update process and limited warranty. Receipt of software Fixes or other enhancements shall not serve to extend the limited warranty period.

For purposes of this warranty the following definitions shall apply: (1) "Fix(es)" means an error correction or other update created to fix a previous software version that does not substantially conform to its Trimble specifications; (2) "Minor Update" occurs when enhancements are made to current features in a software program; and (3) "Major Upgrade" occurs when significant new features are added to software, or when a new product containing new features replaces the further development of a current product line. Trimble reserves the right to determine, in its sole discretion, what constitutes a Fix, Minor Update, or Major Upgrade.

This Trimble software contains Qt 4.5 libraries licensed under the GNU Lesser General Public License (LGPL). The source is available from <http://qt.nokia.com/downloads>. A copy of the LGPL license is included in the appendices of this manual, and at [ftp://ftp.trimble.com/pub/open\\_source/FmX](ftp://ftp.trimble.com/pub/open_source/FmX).

This software includes the DejaVu fonts, which are licensed under the Bitstream Vera license, terms available at <http://dejavu-fonts.org/wiki/index.php?title=License> and <http://www.gnome.org/fonts/>.

## GNU LESSER GENERAL PUBLIC LICENSE

Version 2.1, February 1999

Copyright © 1991, 1999 Free Software Foundation, Inc.

51 Franklin Street, Fifth Floor, Boston, MA 02110-1301  
USA

Everyone is permitted to copy and distribute verbatim copies of this license document, but changing it is not allowed. [This is the first released version of the Lesser GPL. It also counts as the successor of the GNU Library Public License, version 2, hence the version number 2.1.]

### Preamble

The licenses for most software are designed to take away your freedom to share and change it. By contrast, the GNU General Public Licenses are intended to guarantee your freedom to share and change free software—to make sure the software is free for all its users.

This license, the Lesser General Public License, applies to some specially designated software packages—typically libraries—of the Free Software Foundation and other authors who decide to use it. You can use it too, but we suggest you first think carefully about whether this license or the ordinary General Public License is the better strategy to use in any particular case, based on the explanations below.

When we speak of free software, we are referring to freedom of use, not price. Our General Public Licenses are designed to make sure that you have the freedom to distribute copies of free software (and charge for this service if you wish); that you receive source code or can get it if you want it; that you can change the software and use pieces of it in new free programs; and that you are informed that you can do these things.

To protect your rights, we need to make restrictions that forbid distributors to deny you these rights or to ask you to surrender these rights. These restrictions translate to certain responsibilities for you if you distribute copies of the library or if you modify it.

For example, if you distribute copies of the library, whether gratis or for a fee, you must give the recipients all the rights that we gave you. You must make sure that they, too, receive or can get the source code. If you link other code with the library, you must provide complete object files to the recipients, so that they can relink them with the library after making changes to the library and recompiling it. And you must show them these terms so they know their rights.

We protect your rights with a two-step method: (1) we copyright the library, and (2) we offer you this license, which gives you legal permission to copy, distribute and/or modify the library.

To protect each distributor, we want to make it very clear that there is no warranty for the free library. Also, if the library is modified by someone else and passed on, the recipients should know that what they have is not the original version, so that the original author's reputation will not be affected by problems that might be introduced by others.

Finally, software patents pose a constant threat to the existence of any free program. We wish to make sure that a company cannot effectively restrict the users of a free program by obtaining a restrictive license from a patent holder. Therefore, we insist that any patent license obtained for a version of the library must be consistent with the full freedom of use specified in this license.

Most GNU software, including some libraries, is covered by the ordinary GNU General Public License. This license, the GNU Lesser General Public License, applies to certain designated libraries, and is quite different from the ordinary General Public License. We use this license for certain libraries in order to permit linking those libraries into non-free programs.

When a program is linked with a library, whether statically or using a shared library, the combination of the two is legally speaking a combined work, a derivative of the original library. The ordinary General Public License therefore permits such linking only if the entire combination fits its criteria of freedom. The Lesser General Public License permits more lax criteria for linking other code with the library.

We call this license the "Lesser" General Public License because it does Less to protect the user's freedom than the ordinary General Public License. It also provides other free software developers Less of an advantage over competing non-free programs. These disadvantages are the reason we use the ordinary General Public License for many libraries. However, the Lesser license provides advantages in certain special circumstances.

For example, on rare occasions, there may be a special need to encourage the widest possible use of a certain library, so that it becomes a de-facto standard. To achieve this, non-free programs must be allowed to use the library. A more frequent case is that a free library does the same job as widely used non-free libraries. In this case, there is little to gain by limiting the free library to free software only, so we use the Lesser General Public License.

In other cases, permission to use a particular library in nonfree programs enables a greater number of people to use a large body of free software. For example, permission to use the GNU C Library in non-free programs enables many more people to use the whole GNU operating system, as well as its variant, the GNU/Linux operating system.

Although the Lesser General Public License is Less protective of the users' freedom, it does ensure that the user of a program that is linked with the Library has the freedom and the wherewithal to run that program using a modified version of the Library.

The precise terms and conditions for copying, distribution and modification follow. Pay close attention to the difference between a "work based on the library" and a "work that uses the library". The former contains code derived from the library, whereas the latter must be combined with the library in order to run.

## GNU LESSER GENERAL PUBLIC LICENSE

### TERMS AND CONDITIONS FOR COPYING, DISTRIBUTION AND MODIFICATION

0. This License Agreement applies to any software library or other program which contains a notice placed by the copyright holder or other authorized party saying it may be distributed under the terms of this Lesser General Public License (also called "this License"). Each licensee is addressed as "you".

A "library" means a collection of software functions and/or data prepared so as to be conveniently linked with application programs (which use some of those functions and data) to form executables.

The "Library", below, refers to any such software library or work which has been distributed under these terms. A "work based on the Library" means either the Library or any derivative work under copyright law: that is to say, a work containing the Library or a portion of it, either verbatim or with modifications and/or

translated straightforwardly into another language. (Hereinafter, translation is included without limitation in the term "modification".)

"Source code" for a work means the preferred form of the work for making modifications to it. For a library, complete source code means all the source code for all modules it contains, plus any associated interfacedefinition files, plus the scripts used to control compilation and installation of the library.

Activities other than copying, distribution and modification are not covered by this License; they are outside its scope. The act of running a program using the Library is not restricted, and output from such a program is covered only if its contents constitute a work based on the Library (independent of the use of the Library in a tool for writing it). Whether that is true depends on what the Library does and what the program that uses the Library does.

1. You may copy and distribute verbatim copies of the Library's complete source code as you receive it, in any medium, provided that you conspicuously and appropriately publish on each copy an appropriate copyright notice and disclaimer of warranty; keep intact all the notices that refer to this License and to the absence of any warranty; and distribute a copy of this License along with the Library.

You may charge a fee for the physical act of transferring a copy, and you may at your option offer warranty protection in exchange for a fee.

2. You may modify your copy or copies of the Library or any portion of it, thus forming a work based on the Library, and copy and distribute such modifications or work under the terms of Section 1 above, provided that you also meet all of these conditions:

a) The modified work must itself be a software library.

b) You must cause the files modified to carry prominent notices stating that you changed the files and the date of any change.

c) You must cause the whole of the work to be licensed at no charge to all third parties under the terms of this License.

d) If a facility in the modified Library refers to a function or a table of data to be supplied by an application program that uses the facility, other than as an argument passed when the facility is invoked, then you must make a good faith effort to ensure that, in the event an application does not supply such function or table, the facility still operates, and performs whatever part of its purpose remains meaningful.

(For example, a function in a library to compute square roots has a purpose that is entirely well-defined independent of the application. Therefore, Subsection 2d requires that any application-supplied function or table used by this function must be optional: if the application does not supply it, the square root function must still compute square roots.)

These requirements apply to the modified work as a whole. If identifiable sections of that work are not derived from the Library, and can be reasonably considered independent and separate works in themselves, then this License, and its terms, do not apply to those sections when you distribute them as separate works. But when you distribute the same sections as part of a whole which is a work based on the Library, the distribution of the whole must be on the terms of this License, whose permissions for other licensees extend to the entire whole, and thus to each and every part regardless of who wrote it.

Thus, it is not the intent of this section to claim rights or contest your rights to work written entirely by you; rather, the intent is to exercise the right to control the distribution of derivative or collective works based on the Library.

In addition, mere aggregation of another work not based on the Library with the Library (or with a work based on the Library) on a volume of a storage or distribution medium does not bring the other work under the scope of this License.

3. You may opt to apply the terms of the ordinary GNU General Public License instead of this License to a given copy of the Library. To do this, you must alter all the notices that refer to this License, so that they refer to the ordinary GNU General Public License, version 2, instead of to this License. (If a newer version than version 2 of the ordinary GNU General Public License has appeared, then you can specify that version instead if you wish.) Do not make any other change in these notices.

Once this change is made in a given copy, it is irreversible for that copy, so the ordinary GNU General Public License applies to all subsequent copies and derivative works made from that copy.

This option is useful when you wish to copy part of the code of the Library into a program that is not a library.

4. You may copy and distribute the Library (or a portion or derivative of it, under Section 2) in object code or executable form under the terms of Sections 1 and 2 above provided that you accompany it with the complete corresponding machine-readable source code, which must be distributed under the terms of Sections 1 and 2 above on a medium customarily used for software interchange.

If distribution of object code is made by offering access to copy from a designated place, then offering equivalent access to copy the source code from the same place satisfies the requirement to distribute the source code, even though third parties are not compelled to copy the source along with the object code.

5. A program that contains no derivative of any portion of the Library, but is designed to work with the Library by being compiled or linked with it, is called a "work that uses the Library". Such a work, in isolation, is not a derivative work of the Library, and therefore falls outside the scope of this License.

However, linking a "work that uses the Library" with the Library creates an executable that is a derivative of the Library (because it contains portions of the Library), rather than a "work that uses the library". The executable is therefore covered by this License. Section 6 states terms for distribution of such executables.

When a "work that uses the Library" uses material from a header file that is part of the Library, the object code for the work may be a derivative work of the Library even though the source code is not. Whether this is true is especially significant if the work can be linked without the Library, or if the work is itself a library. The threshold for this to be true is not precisely defined by law.

If such an object file uses only numerical parameters, data structure layouts and accessors, and small macros and small inline functions (ten lines or less in length), then the use of the object file is unrestricted, regardless of whether it is legally a derivative work. (Executables containing this object code plus portions of the Library will still fall under Section 6.)

Otherwise, if the work is a derivative of the Library, you may distribute the object code for the work under the terms of Section 6. Any executables containing that work also fall under Section 6, whether or not they are linked directly with the Library itself.

6. As an exception to the Sections above, you may also combine or link a "work that uses the Library" with the Library to produce a work containing portions of the Library, and distribute that work under terms of your choice, provided that the terms permit modification of the work for the customer's own use and reverse engineering for debugging such modifications.

You must give prominent notice with each copy of the work that the Library is used in it and that the Library and its use are covered by this License. You must supply a copy of this License. If the work during execution displays copyright notices, you must include the copyright notice for the Library among them, as well as a reference directing the user to the copy of this License. Also, you must do one of these things:

a) Accompany the work with the complete corresponding machine-readable source code for the Library including whatever changes were used in the work (which must be distributed under Sections 1 and 2 above); and, if the work is an executable linked with the Library, with the complete machine-readable "work that uses the Library", as object code and/or source code, so that the user can modify the Library and then relink to produce a modified executable containing the modified Library. (It is understood that the user who changes the contents of definitions files in the Library will not necessarily be able to recompile the application to use the modified definitions.)

b) Use a suitable shared library mechanism for linking with the Library. A suitable mechanism is one that (1) uses at run time a copy of the library already present on the user's computer system, rather than copying library functions into the executable, and (2) will operate properly with a modified version of the library, if the user installs one, as long as the modified version is interface-compatible with the version that the work was made with.

c) Accompany the work with a written offer, valid for at least three years, to give the same user the materials specified in Subsection 6a, above, for a charge no more than the cost of performing this distribution.

d) If distribution of the work is made by offering access to copy from a designated place, offer equivalent access to copy the above specified materials from the same place.

e) Verify that the user has already received a copy of these materials or that you have already sent this user a copy.

For an executable, the required form of the "work that uses the Library" must include any data and utility programs needed for reproducing the executable from it. However, as a special exception, the materials to be distributed need not include anything that is normally distributed (in either source or binary form) with the major components (compiler, kernel, and so on) of the operating system on which the executable runs, unless that component itself accompanies the executable.

It may happen that this requirement contradicts the license restrictions of other proprietary libraries that do not normally accompany the operating system. Such a contradiction means you cannot use both them and the Library together in an executable that you distribute.

7. You may place library facilities that are a work based on the Library side-by-side in a single library together with other library facilities not covered by this License, and distribute such a combined library, provided that the separate distribution of the work based on the Library and of the other library facilities is otherwise permitted, and provided that you do these two things:

a) Accompany the combined library with a copy of the same work based on the Library, uncombined with any other library facilities. This must be distributed under the terms of the Sections above.

b) Give prominent notice with the combined library of the fact that part of it is a work based on the Library, and explaining where to find the accompanying uncombined form of the same work.

8. You may not copy, modify, sublicense, link with, or distribute the Library except as expressly provided under this License. Any attempt otherwise to copy, modify, sublicense, link with, or distribute the Library is void, and will automatically terminate your rights under this License. However, parties who have received copies, or rights, from you under this License will not have their licenses terminated so long as such parties remain in full compliance.

9. You are not required to accept this License, since you have not signed it. However, nothing else grants you permission to modify or distribute the Library or its derivative works. These actions are prohibited by law if you do not accept this License. Therefore, by modifying or distributing the Library (or any work based on the Library), you indicate your acceptance of this License to do so, and all its terms and conditions for copying, distributing or modifying the Library or works based on it.

10. Each time you redistribute the Library (or any work based on the Library), the recipient automatically receives a license from the original licensor to copy, distribute, link with or modify the Library subject to these terms and conditions. You may not impose any further restrictions on the recipients' exercise of the rights granted herein. You are not responsible for enforcing compliance by third parties with this License.

## Warranty Remedies

Trimble's sole liability and your exclusive remedy under the warranties set forth above shall be, at Trimble's option, to repair or replace any Product that fails to conform to such warranty ("Nonconforming Product"), and/or issue a cash refund up to the purchase price paid by you for any such Nonconforming Product, excluding costs of installation, upon your return of the Nonconforming Product to Trimble in accordance with Trimble's product return procedures then in effect. Such remedy may include reimbursement of the cost of repairs for damage to third-party equipment onto which the Product is installed, if such damage is found to be directly caused by the Product as reasonably determined by Trimble following a root cause analysis.

## Warranty Exclusions and Disclaimer

These warranties shall be applied only in the event and to the extent that (a) the Products and Software are properly and correctly installed, configured, interfaced, maintained, stored, and operated in accordance with Trimble's relevant operator's manual and specifications, and; (b) the Products and Software are not modified or misused. The preceding warranties shall not apply to, and Trimble shall not be responsible for defects or performance problems resulting from (i) the combination or utilization of the Product or Software with hardware or software products, information, data, systems, interfaces or devices not made, supplied or specified by Trimble; (ii) the operation of the Product or Software under any specification other than, or in addition to, Trimble's standard specifications for its products; (iii) the unauthorized, installation, modification, or use of the Product or Software; (iv) damage caused by accident, lightning or other electrical discharge, fresh or salt water immersion or spray (outside of Product specifications); or (v) normal wear and tear on consumable parts (e.g., batteries). Trimble does not warrant or guarantee the results obtained through the use of the Product or that software components will operate error free.

THE WARRANTIES ABOVE STATE TRIMBLE'S ENTIRE LIABILITY, AND YOUR EXCLUSIVE REMEDIES, RELATING TO THE PRODUCTS AND SOFTWARE. EXCEPT AS OTHERWISE EXPRESSLY PROVIDED HEREIN, THE PRODUCTS, SOFTWARE, AND ACCOMPANYING DOCUMENTATION AND MATERIALS ARE PROVIDED "AS-IS" AND WITHOUT EXPRESS OR IMPLIED WARRANTY OF ANY KIND BY EITHER TRIMBLE NAVIGATION LIMITED OR ANYONE WHO HAS BEEN INVOLVED IN ITS CREATION, PRODUCTION, INSTALLATION, OR DISTRIBUTION INCLUDING, BUT NOT LIMITED TO, THE IMPLIED WARRANTIES OF MERCHANTABILITY AND FITNESS FOR A PARTICULAR PURPOSE, TITLE, AND NONINFRINGEMENT. THE STATED EXPRESS WARRANTIES ARE IN LIEU OF ALL OBLIGATIONS OR LIABILITIES ON THE PART OF TRIMBLE ARISING OUT OF, OR IN CONNECTION WITH, ANY PRODUCTS OR SOFTWARE. BECAUSE SOME STATES AND JURISDICTIONS DO NOT ALLOW LIMITATIONS ON DURATION OR THE EXCLUSION OF AN IMPLIED WARRANTY, THE ABOVE LIMITATION MAY NOT APPLY OR FULLY APPLY TO YOU.

NOTICE REGARDING PRODUCTS EQUIPPED WITH TECHNOLOGY CAPABLE OF TRACKING SATELLITE SIGNALS FROM SATELLITE BASED AUGMENTATION SYSTEMS (SBAS) (WAAS/EGNOS, AND MSAS), OMNISTAR, GPS, MODERNIZED GPS OR GLONASS SATELLITES, OR FROM IALA BEACON SOURCES: TRIMBLE IS NOT RESPONSIBLE FOR THE OPERATION OR FAILURE OF OPERATION OF ANY SATELLITE BASED POSITIONING SYSTEM OR THE AVAILABILITY OF ANY SATELLITE BASED POSITIONING SIGNALS.

## Limitation of Liability

TRIMBLE'S ENTIRE LIABILITY UNDER ANY PROVISION HEREIN SHALL BE LIMITED TO THE AMOUNT PAID BY YOU FOR THE PRODUCT OR SOFTWARE LICENSE. TO THE MAXIMUM EXTENT PERMITTED BY APPLICABLE LAW, IN NO EVENT SHALL TRIMBLE OR ITS SUPPLIERS BE LIABLE FOR ANY INDIRECT, SPECIAL, INCIDENTAL OR CONSEQUENTIAL DAMAGES WHATSOEVER UNDER ANY CIRCUMSTANCE OR LEGAL THEORY RELATING IN ANY WAY TO THE PRODUCTS, SOFTWARE AND ACCOMPANYING DOCUMENTATION AND MATERIALS, (INCLUDING, WITHOUT LIMITATION, DAMAGES FOR LOSS OF BUSINESS PROFITS, BUSINESS INTERRUPTION, LOSS OF BUSINESS INFORMATION, OR ANY OTHER PECUNIARY LOSS), REGARDLESS WHETHER TRIMBLE HAS BEEN ADVISED OF THE POSSIBILITY OF ANY SUCH LOSS AND REGARDLESS OF THE COURSE OF DEALING WHICH DEVELOPS OR HAS DEVELOPED BETWEEN YOU AND TRIMBLE. BECAUSE SOME STATES AND JURISDICTIONS DO NOT ALLOW THE EXCLUSION OR LIMITATION OF LIABILITY FOR CONSEQUENTIAL OR INCIDENTAL DAMAGES, THE ABOVE LIMITATION MAY NOT APPLY OR FULLY APPLY TO YOU.

PLEASE NOTE: THE ABOVE TRIMBLE LIMITED WARRANTY PROVISIONS WILL NOT APPLY TO PRODUCTS PURCHASED IN THOSE JURISDICTIONS (E.G., MEMBER STATES OF THE EUROPEAN ECONOMIC AREA) IN WHICH PRODUCT WARRANTIES ARE THE RESPONSIBILITY OF THE LOCAL DEALER FROM WHOM THE PRODUCTS ARE ACQUIRED. IN SUCH A CASE, PLEASE CONTACT YOUR TRIMBLE DEALER FOR APPLICABLE WARRANTY INFORMATION.

## Official Language

THE OFFICIAL LANGUAGE OF THESE TERMS AND CONDITIONS IS ENGLISH. IN THE EVENT OF A CONFLICT BETWEEN ENGLISH AND OTHER LANGUAGE VERSIONS, THE ENGLISH LANGUAGE SHALL CONTROL.

## Registration

To receive information regarding updates and new products, please contact your local dealer or visit the Trimble website at [www.trimble.com/register](http://www.trimble.com/register). Upon registration you may select the newsletter, upgrade, or new product information you desire.

## Notices

This equipment has been tested and found to comply with the limits for a Class A digital device, pursuant to Part 15 of the FCC rules. These limits are designed to provide reasonable protection against harmful interference when the equipment is operated in a commercial environment. This equipment generates, uses, and can radiate radio frequency energy and, if not installed and used in accordance with the instruction manual, may cause harmful interference to radio communications. Operation of this equipment in a residential area is likely to cause harmful interference, in which case the user will be required to correct the interference at his own expense.

Properly shielded and grounded cables and connectors must be used in order to meet FCC emission limits. TRIMBLE is not responsible for any radio or television interference caused by using other than recommended cables and connectors or by unauthorized changes or modifications to this equipment. Unauthorized changes or modifications could void the user's authority to operate the equipment.

This device complies with Part 15 of the FCC rules. Operation is subject to the following two conditions:

(1) this device may not cause harmful interference, and (2) this device must accept any interference received, including interference that may cause undesired operation.

Responsible Party:

Trimble Navigation  
935 Stewart Drive  
Sunnyvale CA 94085  
Telephone: 1-408 481 8000

### Canada

This Class B digital apparatus complies with Canadian ICES-003. Cet appareil numérique de la classe B est conforme à la norme NMB-003 du Canada.

This apparatus complies with Canadian RSS-GEN, RSS-310, RSS-210, and RSS-119.

Cet appareil est conforme à la norme CNR-GEN, CNR-310, CNR-210, et CNR-119 du Canada.

### Australia and New Zealand Class A Statement

Attention: This is a Class A product. In a domestic environment this product may cause radio interference in which case the user may be required to take adequate measures.

### Australia and New Zealand

This product conforms with the regulatory requirements of the Australian Communications Authority (ACA) EMC framework, thus satisfying the requirements for C-Tick Marking and sale within Australia and New Zealand.



### Notice to Our European Union Customers

For product recycling instructions and more information, please go to [www.trimble.com/ev.shtml](http://www.trimble.com/ev.shtml).

Recycling in Europe: To recycle Trimble WEEE (Waste Electrical and Electronic Equipment, products that run on electrical power.), Call +31 497 53 24 30, and ask for the "WEEE Associate". Or, mail a request for recycling instructions to:



Trimble Europe BV  
c/o Menlo Worldwide Logistics  
Meerheide 45  
5521 DZ Eersel, NL

# Safety Information

Always follow the instructions that accompany a Warning or Caution. The information they provide is intended to minimize the risk of personal injury and/or damage to property. In particular, observe safety instructions that are presented in the following format:

---

 **WARNING** – This alert warns of a potential hazard which, if not avoided, can cause severe injury.

---

 **CAUTION** – This alert warns of a hazard or unsafe practice which, if not avoided, can cause injury or damage.

---

**Note** – An absence of specific alerts does not mean that there are no safety risks involved.

## Warnings

---

 **WARNING** – Anhydrous ammonia (NH<sub>3</sub>) can cause severe burning, blindness, or death. Before you begin to operate or service equipment that contains NH<sub>3</sub>, carefully read and follow all safety instructions in [Working with anhydrous ammonia, page 7](#).

---

 **WARNING** – Incorrect adjustment of the Manual Override Sensitivity calibration setting could cause this critical safety feature to fail, resulting in personal injury or damage to the vehicle. Any adjustment to this setting should only be made by an experienced user.

---

 **WARNING** – During the Deadzone calibration, the system moves the vehicle's steering wheels. To avoid injury, be prepared for sudden vehicle movement.

---

 **WARNING** – When you tap the liquid flow calibration **Start** button, the machine will become operational. Take all necessary precautions to ensure user safety. Failure to do so may result in serious injury or death.

---

 **WARNING** – When you tap the control valve calibration **Start** button, the machine will become operational. Take all necessary precautions to ensure user safety. Failure to do so may result in serious injury or death.

---

 **WARNING** – When you tap the fill disk **Start** button, the machine becomes operational. Take all necessary precautions to ensure user safety. Failure to do so may result in serious injury or death.

---

 **WARNING** – When the implement is down and the master switch is in the On position, the machine is fully operational. Take all necessary precautions to ensure user safety. Failure to do so could result in injury or death.

---



---

**WARNING** – The display contains a single-use Lithium-sulfide  $\text{LiSO}^2$  battery. Do not expose the battery to temperatures greater than 71 °C (160 °F) as the battery may explode.

---



---

**WARNING – MOVING PARTS DURING THIS TEST!** Please stay clear of the implement. Ensure the implement is raised, the transmission is in PARK, and the emergency brake is applied before continuing.

---

## Working with anhydrous ammonia

- Contact your  $\text{NH}_3$  supplier to review all safety requirements associated with anhydrous ammonia ( $\text{NH}_3$ ).
- Always wear correct personal protective equipment. This includes, but is not limited to:
  - Goggles or face shield
  - Protective suit and gloves
  - Respirator
- **Do not** allow anyone to operate the system without proper instruction and training.
- Stand up-wind when working around  $\text{NH}_3$  and related equipment.
- Always keep  $\text{NH}_3$  equipment away from buildings, livestock, and other people.
- Never work on  $\text{NH}_3$  equipment in confined spaces.
- Before you attempt to transport the implement, discharge the system of all  $\text{NH}_3$  and completely shut down the system. See [Discharging the system, page 8](#).
- If symptoms of illness occur during or shortly after use of  $\text{NH}_3$  products, seek immediate medical attention.
- Keep a source of clean water (at least five gallons) readily available. In case of exposure, flush exposed skin or eyes immediately with large quantities of water and seek immediate medical attention.
- $\text{NH}_3$  can be harmful to the environment if not used correctly. Follow all local, state, and federal regulations regarding proper handling of this chemical.

## Servicing the equipment

1. Remove the system from operation before performing any maintenance.
2. Thoroughly bleed all system lines and disconnect the nurse tank hose. See [Discharging the system, page 8](#).
3. Make sure that the gauge pressure is at zero before you open the system.
4. Use extreme caution when opening a previously pressurized system.

## Discharging the system

1. Turn off the console or vehicle master switch.
2. Completely close the main shut-off valve on the supply or nurse tank.
3. Resume field application until the pressure gauge shows zero pressure.
4. Check again that the console and/or vehicle master switch, and all section switches, are turned off.
5. Completely close the emergency shut-off valve the cooling tower.
6. Bleed and disconnect the nurse tank supply hose from the system.
7. Turn on the console master switch and all section switches.
8. Stand up-wind from the implement and then slowly open the bleed valve(s) until fully open.
9. Allow at least one (1) hour for the system to fully discharge.
10. Before you open the system, make sure that the pressure gauge on the manifold reads zero and that the cooling tower is not cold to the touch. This ensures that all liquid NH<sub>3</sub> has evaporated and that the pressure is discharged.

**Note** – Frost on any component is a positive indication of trapped NH<sub>3</sub> at low pressure. Lack of frost does not always indicate a lack of NH<sub>3</sub>.



# Contents

<b>Legal Notices</b>	<b>2</b>
<b>Safety Information</b>	<b>6</b>
Warnings	6
Working with anhydrous ammonia	7
Servicing the equipment	7
Discharging the system	8
<b>1 Introduction</b>	<b>14</b>
About the FM-750 display	14
Related information	14
Technical assistance	14
<b>2 Installing the Display and Antenna</b>	<b>15</b>
System components	16
Installing the display	17
Connecting the display	18
Connecting a standalone FM-750 display for WAAS/EGNOS/ OmniSTAR XP/HP corrections	19
Connecting a standalone FM-750 display for RTK corrections	20
Installing the antenna	21
<b>3 Getting Started</b>	<b>22</b>
Display basics	23
Front view	23
Back view	24
Cleaning the touchscreen	25
Power up	25
Power down	26
Resetting the display	26
The USB socket	27
Removing a USB drive	28
Taking a screenshot	29
The Quick Start Wizard	29
Using the setup wizards	30
The guidance screen	31
Status	31
Settings	32
View	32
Extended icons	34
Quick Access icon	34
The Field icon	36
The Guidance icon	37
The Mapping icon	37
The Auto steer icon	37
Reading lightbar patterns	37
Using the EZ-Remote joystick	38
On-screen icons	38
<b>4 Vehicle</b>	<b>42</b>
Introduction	43
The EZ-Steer assisted steering system	44

Setup . . . . .	44
Calibration . . . . .	46
Operation. . . . .	49
The EZ-Pilot steering system . . . . .	52
Setup . . . . .	52
Calibration . . . . .	54
Operation. . . . .	57
The Autopilot automated steering system. . . . .	66
Setup . . . . .	66
Operation. . . . .	66
<b>5 Implement Application Controller . . . . .</b>	<b>68</b>
Introduction . . . . .	69
Prescriptions . . . . .	70
HARDI 5500 controller. . . . .	72
Setup . . . . .	72
Advanced . . . . .	72
Operation. . . . .	74
Raven controllers . . . . .	75
Setup . . . . .	76
Advanced . . . . .	76
Operation. . . . .	78
Rawson controller . . . . .	79
Setup . . . . .	79
Advanced . . . . .	79
Operation. . . . .	82
Amazone controller . . . . .	83
Setup . . . . .	83
Advanced . . . . .	83
Operation. . . . .	85
LH 5000 controller . . . . .	86
Setup . . . . .	86
Advanced . . . . .	86
Operation. . . . .	88
Vaderstad controller. . . . .	89
Setup . . . . .	89
Advanced . . . . .	89
Single section boom switching . . . . .	91
Bogballe controller . . . . .	91
Setup . . . . .	91
Advanced . . . . .	92
Single section boom switching . . . . .	93
Checking the implement connection. . . . .	93
<b>6 Field-IQ Crop Input Control System . . . . .</b>	<b>95</b>
Overview . . . . .	96
Definitions . . . . .	96
Units of measure. . . . .	97
Installing the Field-IQ hardware . . . . .	97
Setting up the Field-IQ system . . . . .	98
Setting up the Implement and Control type. . . . .	98
Setting up the Implement Operation and Implement Layout . . . . .	99
Setting up the Implement Measurements. . . . .	100
Setting up the Implement Switches . . . . .	102
Setting up a Material . . . . .	103
Setting up a Row Crop Seed in the Material Setup screen . . . . .	105

Setting up a Location . . . . .	109
Field-IQ Hydraulics Test . . . . .	121
Field-IQ System Status. . . . .	122
Material Assignment screen . . . . .	122
Operation. . . . .	123
Field-IQ master switch box . . . . .	125
Field-IQ 12-section switch box . . . . .	126
<b>7 Field-IQ Boom Height Control System . . . . .</b>	<b>127</b>
Installing the Boom Height Control hardware. . . . .	128
Setting up the Boom Height Control system. . . . .	128
Calibrating the Field-IQ Boom Height system . . . . .	134
Using the Boom Height Control system . . . . .	135
Monitoring boom height . . . . .	135
Enabling a control zone . . . . .	136
Engaging enabled zones. . . . .	137
Adjusting the Target Height and Aggressiveness Controls . . . . .	138
Disengaging engaged zones. . . . .	139
Disabling Boom Height Control . . . . .	139
<b>8 Yield Monitoring System . . . . .</b>	<b>141</b>
Setting up the Yield Monitoring system . . . . .	142
Calibration . . . . .	151
Set up calibrations . . . . .	151
Header Height Calibration . . . . .	151
Moisture Sensor Calibration . . . . .	152
Tare Calibration . . . . .	153
Temperature Calibration . . . . .	154
Roll Calibration. . . . .	154
In field calibrations . . . . .	156
Yield flow calibration . . . . .	156
In field operations . . . . .	161
Status items . . . . .	165
<b>9 Mapping and Guidance . . . . .</b>	<b>166</b>
Introduction . . . . .	167
Configuring the Guidance settings . . . . .	167
Turn Settings . . . . .	168
Coverage Settings . . . . .	168
Nudge Settings. . . . .	169
Mapping . . . . .	169
FreeForm Recording. . . . .	170
Headland/Infill Switching . . . . .	170
Boundary setup . . . . .	170
Starting Guidance . . . . .	171
Implement Setup options. . . . .	171
Using guidance on curved segments . . . . .	172
Using guidance on straight segments . . . . .	173
Creating straight sections on Headland or Curve swaths. . . . .	173
Fields . . . . .	173
Creating a new field . . . . .	173
Adding an AB line to a current field . . . . .	173
Selecting (loading) an AB line into a field . . . . .	174
Record keeping. . . . .	174
Resetting guidance. . . . .	175
Guidance lines . . . . .	175

Distance between guidance lines. . . . .	175
Headlands . . . . .	175
On screen appearance. . . . .	176
Guidance patterns . . . . .	176
Straight AB . . . . .	177
A+ line . . . . .	177
Identical curve . . . . .	178
Adaptive curve . . . . .	178
Pivot . . . . .	179
Headland . . . . .	179
FreeForm . . . . .	181
Line Feature Guidance. . . . .	183
Coverage logging. . . . .	184
The pause / resume function . . . . .	184
Curve smoothing. . . . .	185
<b>10 GPS. . . . .</b>	<b>.186</b>
Introduction . . . . .	187
GPS Setup . . . . .	187
Using xFill technology . . . . .	189
Frequency / Baud map . . . . .	190
Position Quality . . . . .	190
Advanced . . . . .	191
Antenna Type . . . . .	191
Use SBAS satellites in the position fix . . . . .	191
Force GPS Iono . . . . .	191
Satellite Health. . . . .	192
Status . . . . .	192
GPS Status . . . . .	192
Satellite Status . . . . .	192
DGPS Status . . . . .	193
<b>11 Data . . . . .</b>	<b>.194</b>
Introduction . . . . .	195
DCM-300 modem . . . . .	195
Passcodes. . . . .	195
Configuring the display for VRS corrections . . . . .	197
Configuring VRS settings . . . . .	198
Connected Farm Setup . . . . .	199
Initial setup. . . . .	199
Device name . . . . .	200
Modem only setup. . . . .	200
Network registration . . . . .	201
Connected Farm data transfer . . . . .	201
Sending Field data using Connected Farm . . . . .	203
Receiving Field data through the Connected Farm service. . . . .	203
Manage Data . . . . .	204
USB . . . . .	204
Clearing the internal memory . . . . .	205
<b>12 System . . . . .</b>	<b>.207</b>
Introduction . . . . .	208
Display . . . . .	208
Units . . . . .	208
Color Scheme . . . . .	209
Time Zone . . . . .	209

View . . . . .	209
Status Popup Transparency . . . . .	210
Backlight . . . . .	210
Touchscreen speaker volume . . . . .	210
Lightbar Setup . . . . .	210
Advanced . . . . .	211
Save/Load Configurations . . . . .	211
Digital Output . . . . .	211
Enable Advanced User Config . . . . .	212
NMEA Output . . . . .	212
EZ-Remote joystick . . . . .	212
EZ-Remote Keypad Assignment Wizard . . . . .	213
EZ-Remote LED Brightness . . . . .	213
EZ-Remote Keypad Assignments . . . . .	213
EZ-Remote operation . . . . .	214
Unlock / Upgrade . . . . .	214
Upgrading your display . . . . .	215
Unlocking features . . . . .	215
Unlocking the CenterPoint RTX correction service . . . . .	215
Unlocking the RangePoint RTX correction service . . . . .	218
Status . . . . .	220
FM-750 screen . . . . .	220
Recalibrate touchscreen . . . . .	221

# Introduction

This manual describes how to install, configure, and use the FM-750™ display, version 4.0.

Even if you have used other Global Navigation Satellite Systems (GNSS) or application control products before, such as the United States' Global Positioning System (GPS) products, it is recommended that you spend some time reading this manual to learn about the special features of this product. If you are not familiar with GNSS, visit the Trimble website ([www.trimble.com](http://www.trimble.com)) for an interactive look at GNSS.

## About the FM-750 display

The FM-750 display is an in-cab touchscreen display that provides affordable guidance, steering and precision agriculture functionality.

The FM-750 display includes a built-in GPS receiver that you can upgrade to receive GLONASS satellite signals. The display can also use an array of components to maximize efficiency when planting, spraying, spreading and strip tilling, including the Field-IQ™ crop input control system.

## Related information

Sources of related information include the following:

- Release notes: The release notes describe new features of the product, information not included in the manuals, and any changes to the manuals. The release notes are available at [www.trimble.com](http://www.trimble.com).
- Trimble training courses: Consider a training course to help you use your GPS system to its fullest potential. For more information, go to the Trimble website at [www.trimble.com/training.html](http://www.trimble.com/training.html).

## Technical assistance

Contact your Reseller for technical assistance.

# Installing the Display and Antenna

## In this chapter:

- [System components](#)
- [Installing the display](#)
- [Connecting the display](#)
- [Installing the antenna](#)

This chapter introduces the FM-750 display and system components, and also describes how to install the display and antenna.

## System components



Item	Description	Case IH Part number	New Holland Part number
1	FM-750 display	94110-20	94110-60
2	RAM mount and screws	61958	61958
3	Quick reference card	78838-20-ENG	78838-60-ENG
4	Compact disc	78821-20	78821-60
5	GPS antenna cable	50449	50449
6	Power bus/CAN cable	77282	77282
7	Power cable	67258	67258
8	AG25 antenna	77038	77038
9	AG25 antenna mount plate	62034	62034



## Installing the display

Mount the FM-750 display in the vehicle cab. When you position the display, make sure that:

- it is within the driver's reach so that the USB drive is easy to remove and replace.
- the touchscreen is easy to see, but the display does not block the driver's view.
- it does not interfere with the driver getting in or out of the cab, or any other activities.

The image shows the mounting assembly for the display:

Item	Description
❶	Diamond-shaped mounting plate
❷	RAM mount
❸	Bar mount

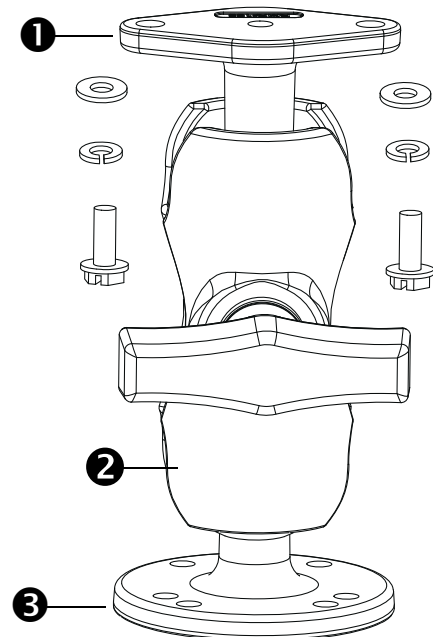

To install the display:

1. Use the supplied screws to firmly attach the diamond-shaped mounting plate to the back of the display:



2. Attach the RAM mount to the ball on the diamond-shaped mounting plate:



3. Select a position in the cab for the display. Hold the display in the selected location and check that it is easily accessible from the driver's seat.
4. Use the provided bolts to attach the bar mount to the cab.
5. Attach the other end of the RAM mount to the ball on the bar mount and then tighten the screw.

## Connecting the display

The diagrams in this section show how to set up the FM-750 display as a standalone system.

To learn how to connect the FM-750 display to other the system components, see the *FM-750 Display Cabling Guide*.

## Connecting a standalone FM-750 display for WAAS/EGNOS/OmniSTAR XP/HP corrections

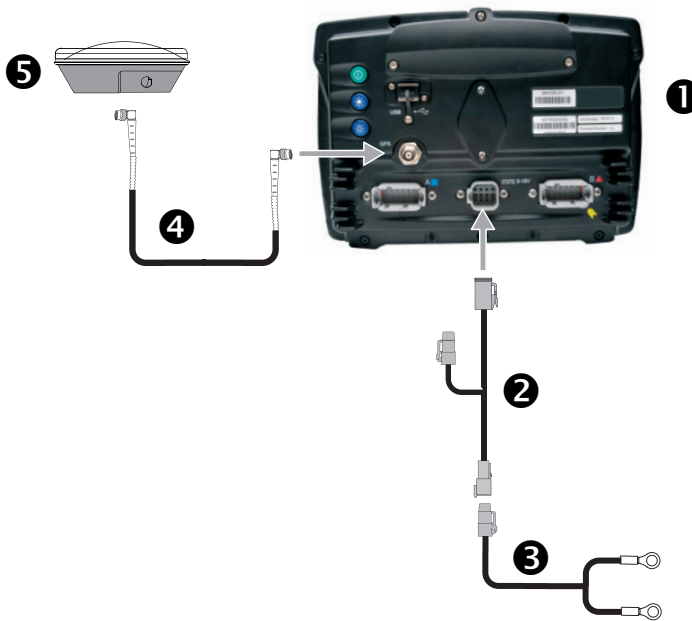

Item	Description	Case IH part number	New Holland part number
1	FM-750 display	94110-20	94110-60
2	FM-750 power cable	77282	77282
3	FM-750 basic power cable	67258-01	67258-01
4	8 m GPS TNC/TNC RT angle cable	50449	50449
5	AG25 GNSS antenna	77038	77038

## Connecting a standalone FM-750 display for RTK corrections

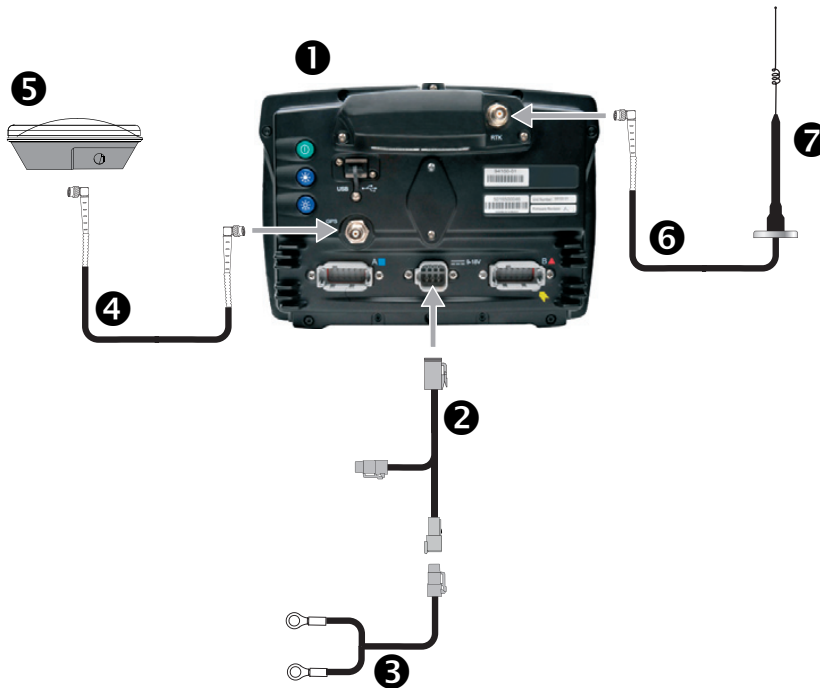

Item	Description	Case IH part number	New Holland part number
1	FM-750 display <i>Note – RTK password required.</i>	94110-20	94110-60
2	FM-750 power cable	77282	77282
3	FM-750 basic power cable	67258-01	67258-01
4	8 m GPS TNC/TNC RT angle cable	50449	50449
5	AG25 GNSS antenna	77038	77038
6	NMO to TNC 20ft antenna cable and base	62120	62120
7	900 MHz radio antenna kit	22882-10	22882-10

## Installing the antenna

**Note** – To minimize any interference to the GPS signal, make sure that the GPS antenna is at least 1 m (3 ft) from any other antenna (including a radio antenna). You may experience interference if you operate the vehicle within 100 m (300 ft) of any power line, radar dish, or cell phone tower.

**Note** – The AG25 antenna has integrated magnets for easy installation. To attach the antenna to a non-metal surface, you must use the mounting plate.

1. Find the mounting location for the antenna at the front of the vehicle roof, centered from left to right.
2. On the mounting plate, remove the protective covers from the adhesive strips.
3. Attach the mounting plate to the vehicle roof with the adhesive strips. Ensure that the mounting plate is centered along the vehicle roof.
4. Connect the antenna cable to the antenna.
5. Place the antenna directly on the mounting plate. The three magnets embedded in the bottom of the antenna will hold it in place.
6. Route the other end of the antenna cable into the cab.

# Getting Started

## In this chapter:

- [Display basics](#)
- [The Quick Start Wizard](#)
- [Using the setup wizards](#)
- [The guidance screen](#)
- [Using the EZ-Remote joystick](#)
- [Reading lightbar patterns](#)
- [On-screen icons](#)

This chapter describes, in general terms, how to use the FM-750 display.

## Display basics

The FM-750 display provides guidance, steering and precision agriculture functionality. The display has a touchscreen that you use to operate your system and to view guidance information. In addition, there is a USB port on the display for loading and saving field data.

### Front view



Item	Description	Notes
❶	8" Touch-sensitive screen	To interact with the system, tap the screen with your finger. For more information, see <a href="#">Recalibrate touchscreen, page 221</a> .
❷	Speaker	You can adjust the speaker volume, or turn it off. For more information, see <a href="#">Touchscreen speaker volume, page 210</a> .
❸	Integrated lightbar with 27 LEDs	When lit, the LEDs show the position of your vehicle relative to your intended guidance line. For more information, see <a href="#">Reading lightbar patterns, page 37</a> .



**CAUTION** – Do not press on the screen with a sharp item, such as a pencil or screwdriver; you may damage the surface of the screen.

## Back view



Item	Description	Notes
❶	Power button	Turns the display on or off.
❷ and ❸	Brightness controls	<ul style="list-style-type: none"> <li>To <b>increase</b> the brightness of the screen, press ❷.</li> <li>To <b>decrease</b> the brightness, press ❸.</li> </ul> <p><b>Note</b> – You can also use the <i>Color Scheme</i> and <i>Backlight</i> menu options to set the screen brightness. See <i>Color Scheme</i>, page 209, and <i>Backlight</i>, page 210.</p>
❹	USB socket	You can connect a USB memory stick to the display to transfer data to and from the unit. For more information, see <a href="#">The USB socket</a> , page 27.
❺	GPS connector	Connects the GPS cable (P/N 50449) to the display.
❻	Port A	Connects external devices to the display.
❼	Power connection socket	Connects the power cable (P/N 67258) to the display.
❽	Port B	Connects external devices to the display.
❾	Radio access panel	If you purchase the optional RTK module, install the module here. For more information, see the installation instructions supplied with the radio module.



## Cleaning the touchscreen

To clean the FM-750 display use the following supplies:

- Ammonia-free glass cleaner

**Note** – *Do not apply glass cleaner directly to the touchscreen.*

- Soft, lint-free cotton cloth
- 50% isopropyl alcohol

1. Apply a small amount of glass cleaner to the cloth and gently rub it against the touchscreen.
2. To clean off any stains or smudges, use a cotton cloth dampened with 50% isopropyl alcohol.

 **Tip** – Clean the display while it is switched off. It is easier to see dirt and fingerprints when the touchscreen is dark.

## Power up

To turn on the display, press the power button on the rear of the display. After a short time, the *Welcome* screen appears:



The first time that you turn on the FM-750 display, the following wizards appear in turn:

- Touchscreen calibration:

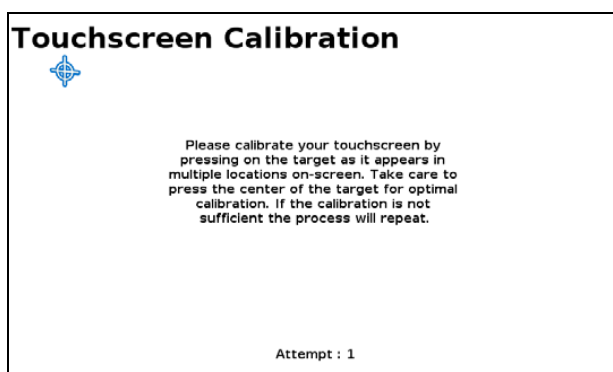

You must calibrate the touchscreen before you can use the display; to do this, follow the onscreen instructions.

- The Quick Start wizard. To configure your system properly, make sure that you run the entire wizard, see [page 29](#).

## Power down

To turn off the FM-750 display, hold down the power button for three seconds. While holding down the power button, the *Power Down In Progress* screen appears:

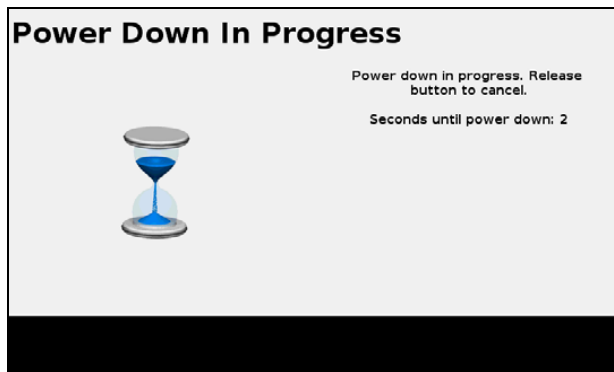

**Note** – To cancel the power down process, release the power button before the three second countdown is complete.

## Resetting the display

Occasionally, you may want to reset the display settings. There are two ways to do this:

- **Soft reset:** This returns all settings to the factory defaults. All saved field data remains intact.
- **Hard reset:** This returns all settings to the factory defaults, **and** deletes all saved data including any field data.

**Note** – Do not perform a hard reset unless it is absolutely necessary or you are instructed to do so by Technical Support.

### Soft reset

1. Power down the display and then power it on.
2. Wait until the status bar at the bottom of the second startup screen is over half full:



3. Press the power button and **top** brightness control button at the same time:



4. Hold the buttons down until the display beeps.

## Hard reset

1. Power down the display and then power it on.
2. Wait until the status bar at the bottom of the second startup screen is over half full:



3. Press the power button and **both** brightness control buttons at the same time:



4. Hold the buttons down until the display beeps.

## The USB socket

The USB socket is on the rear of the display. See [Back view, page 24](#). Use the USB socket to manage your data via a USB drive.

## USB drive compatibility

You can use the following USB drives with the FM-750 display:

- A-Data micro SDHC/SD/USB adapter
- Digital Concepts USB to PC Reader
- Kingston Data Traveler 8 GB
- Lexar Firefly 1 GB
- Lexar Secure II Plus
- ADATA Classic C801 8 GB
- Generic USB - uDHC adapter with Transcend 8 GB microSDHC card
- Kingston Data Traveler 101
- Lexar JumpDrive TwistTurn
- PNY Attache

- PNY Micro Swivel Attache 4 GB
- PNY Mini Attache 8 GB
- SanDisk Cruzer Gator 4 GB
- Toshiba TransMemory U2M-004GTA 4 GB
- PNY Mini Attache 4 GB
- SanDisk Cruzer
- SanDisk Cruzer Micro 1 GB
- Transcend JetFlash

## Inserting a USB drive

1. Rotate the display so you that can see the back of it.
2. Insert the USB drive into the USB socket. When the USB drive is inserted correctly, the USB icon appears on the guidance screen:

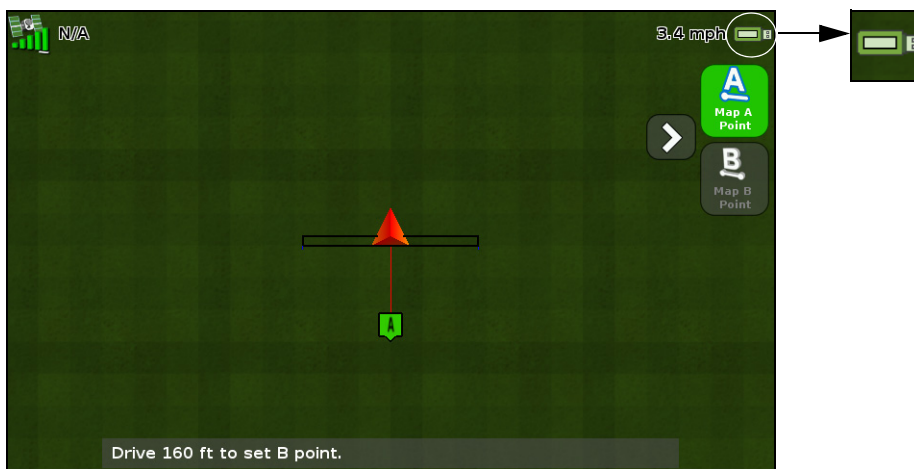

The color of the USB icon indicates the current state of the USB drive:

- Green: the USB drive is connected.
- Yellow: the USB drive is connecting.
- Red: the connection to the USB drive has been lost.

## Removing a USB drive



**CAUTION** – Do not remove the USB drive from the socket while the display is writing to or from the drive. This will corrupt the data.

1. Rotate the display so that you can see the back of it.
2. Pull the USB drive out of the USB socket.

## Taking a screenshot

Occasionally, you may want to save a screenshot of the touchscreen, for example to provide information for troubleshooting purposes. When you take a screenshot, the display saves a .png file to the root directory of the USB drive.

**Note** – Screenshot capability is available only when there is a USB drive inserted in the display.

To take a screenshot:

1. Press **both** brightness control buttons at the same time:



2. Hold the buttons down until the touchscreen flashes.





**CAUTION** – Do not remove the USB drive from the socket while the display is writing to or from the drive. This will corrupt the data.

## The Quick Start Wizard

The Quick Start Wizard enables you to configure important settings before you begin driving. The first time that you turn on the display, the wizard starts automatically. Make sure that when you first turn on the display that you run the entire wizard.

When you run the wizard, you can choose whether or not it appears every time the display is turned on. If you choose to hide the wizard, the guidance screen will appear automatically when you turn the unit on again. However, you can still access the wizard at a later time, as follows:



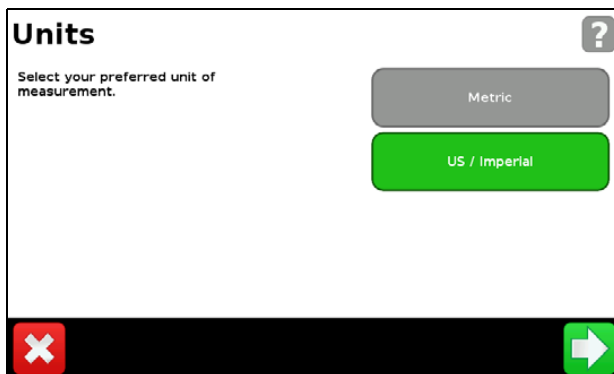





1. Tap  and then tap .
2. Tap **Quick Start Wizard**. The *Welcome* screen appears.
3. Tap . The first page of the Quick Start Wizard appears:



4. To set up your system, complete each page of the wizard. See the section below.

## Using the setup wizards

The FM-750 display contains various wizards that guide you through the task of configuring your system. The following table describes how to use the wizards to enter your system settings.

To ...	Tap ...
Select the setting you require	The field that displays the required value. When you make your selection, the field changes color from gray to green.
Enter the numbers that you require	
Enter text	
Accept the selection and go to the next screen	
Accept the selection and exit the screen	
Navigate the wizard	
Go back to the previous page	
Exit the wizard <i>Note – When you exit the wizard, the system retains any settings you have already selected; for any settings that you have not yet entered, the system uses the settings from the previous configuration.</i>	
Access the on-screen help	

## The guidance screen



The guidance screen displays a mix of text and icons that provide operating information and access to various system functions. The availability of the text and icons depends on the set up of your system. For example, some icons are not available while you are using an auto steer system.

To activate an icon, tap it with your finger. If the display does not respond when you tap it, see [Recalibrate touchscreen, page 221](#).

The following sections describe the icons that can appear on the guidance screen.

## Status

Tap  to scroll through several pop-up screens that describe various system settings:

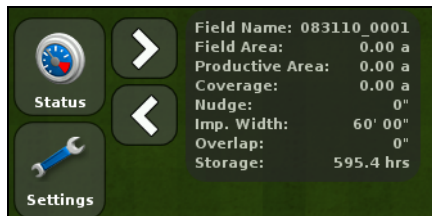

To remove the pop-ups, continue to tap  until they disappear.

## Settings

Tap  to open the *Settings* screen:

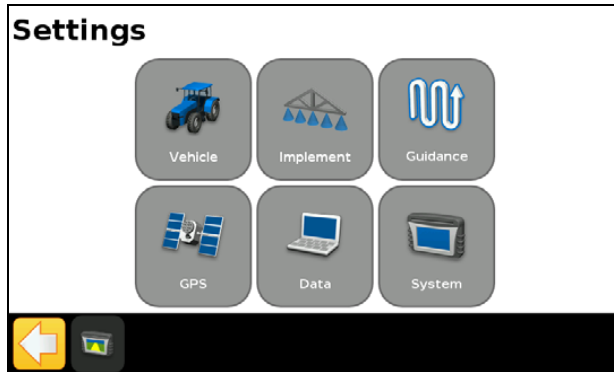

Use the *Settings* screen to adjust your system settings, and view the status of the following:



Setting	For more information, see ...
Vehicle	<a href="#">Chapter 4, Vehicle, page 42</a>
Implement	<a href="#">Chapter 5, Implement Application Controller, page 68</a>
Guidance	<a href="#">Chapter 9, Mapping and Guidance, page 166</a>
GPS	<a href="#">Chapter 10, GPS, page 186</a>
Data	<a href="#">Chapter 11, Data, page 194</a>
System	<a href="#">Chapter 12, System, page 207</a>

## View

The options for viewing the guidance screen are:



- Zoom In
- Zoom Out
- Change View—this toggles between the Overhead view and Trailing view icons.

To:

- **change** the view, tap  and then select the option that you require.
- **exit** a view and return to the guidance screen, tap .

To learn how to change the View settings, see [View, page 209](#).

## Zooming

To zoom in or out on the guidance screen, tap  or .



## Viewing modes

There are two viewing modes, Overhead and Trailing.

By default, the view switches from Overhead to Trailing when you approach the AB line.

To access the Overhead view, tap  .



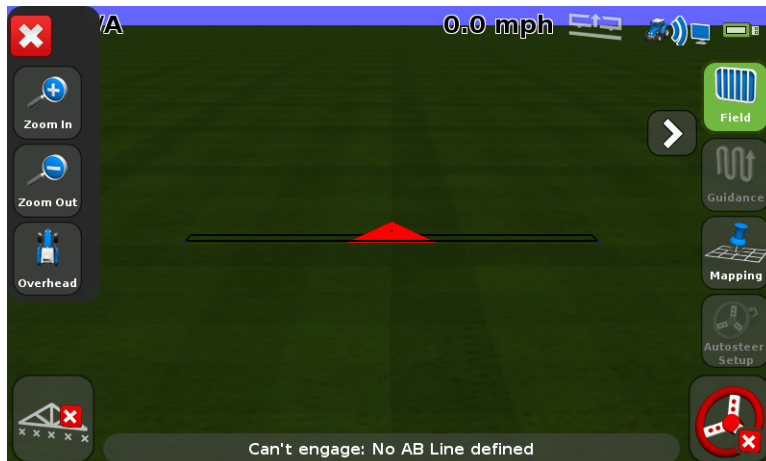

To access the Trailing view, tap  .



## Extended icons

The guidance screen features several extended icons that are hidden in the default view.

To view or hide the extended icons, tap  or .

The following images show how the extended icons appear on the guidance screen when they are expanded and collapsed:



Expanded



Collapsed

## Quick Access icon

You can use the Quick Access icon to quickly adjust common settings.

The items that appear in the Quick Access menu will vary depending on the applications that you are currently running.

The following sections describe the items that may appear.

**Note** – The Quick Access icon appears only when you are running Field-IQ or a variable rate controller.

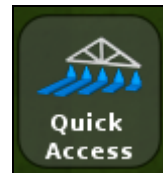

## Boom setup

Use this option to view and adjust the following settings:

Value ...	Notes ...
Implement width	Enter the width of the current implement. The display uses this value to automatically calculated the swath spacing. Enter a width between 1' 00" - 328' 01" (0.30 - 99.99 m).
Boundaries	See <a href="#">Boundary setup, page 170</a> .
Number of sections	Enter the number of sections you want to control on the implement. Enter a number between 1 - 10.

## Refill

Use this option to view and adjust the following settings:

Setting ...	Notes ...
Current volume	Set the current volume of the tank or bin.
Refill method	Select from one of the following options: <ul style="list-style-type: none"> <li>• <b>Refill:</b> To fill the tank or bin to the top</li> <li>• <b>Partial Refill:</b> To add a specified amount to the tank or bin when you select <b>Partial Refill Now</b> from the <i>Refill</i> screen.</li> </ul>
Refill Now / Partial Refill Now	Use this option to refill the tank or bin.

## Section Switching Setup

Use this option to view and adjust the following settings:

Setting ...	Notes ...
Coverage switching overlap	Control the amount of boom switching overlap allowed before the system switches that section. Enter a percentage between 1-99%. For: <ul style="list-style-type: none"> <li>• <b>Less skip:</b> Set a high percentage when total coverage is essential. The system will turn off sections when they cover a larger percentage of any fully covered areas. This may cause some double-coverage. Sections will turn on as soon as they move from a covered to an uncovered area.</li> <li>• <b>Less overlap:</b> Set a low percentage when you need to save product. The system will turn off sections as soon as you reach any covered area. This may leave some skips. Sections will turn on when the entire section has moved from a covered to an uncovered area.</li> </ul>
Refill method	Choose from one of the following options: <ul style="list-style-type: none"> <li>• <b>Refill:</b> to fill the tank or bin to the top</li> <li>• <b>Partial Refill:</b> to add a specified amount to the tank or bin when you select <b>Partial Refill Now</b> from the <i>Refill</i> screen.</li> </ul>
Refill Now / Partial Refill Now	Use this option to refill the tank or bin.

## Boundary switching overlap

Use this option to control the amount of overlap on a boundary before the system switches off the boom section. Enter a percentage between 1-99%.

**Note** – *This setting operates only when the boom is overlapping a headland, pivot boundary, or exclusion zone.*

For:

- **Less skip:** Set a high percentage when it is acceptable to apply outside the boundary.

- **Less overlap:** Set a low percentage when you do not want to apply outside the boundary. A very low setting may cause some skip at the boundary.

## On/off valve latency

This option allows for hardware delays by adjusting the amount of time needed before turning the valves on or off. To use this option:

1. Measure the amount of time it takes (in seconds) for the system to reach the correct rate after you have switched it on or off.
2. Enter a time between 0.0 - 10.0 seconds.

## Intentional overlap

You can use this option to make sure that when applying, there are no gaps in coverage if you move into an uncovered area or out of a covered area.

Use this option ...	To set the distance that you want to travel before...
On overlap distance	<b>Exiting</b> a covered area and switching the implement <b>on</b>
Off overlap distance	<b>Entering</b> a covered area and switching the implement <b>off</b>

## Target rate

Use this option to set the target application rate (the amount of product you want to apply). Enter a number between 1333 - 41333.

## Valve aggressiveness

If you use an auto steer system, such as an EZ-Steer® or Autopilot™ system, you can use this option to adjust how the system responds to steering changes.

Note the following:

- A higher setting brings the vehicle back on line quickly, but may cause tight oscillations.
- A lower setting gives a more moderate response to bringing the vehicle back on line, but can avoid overshoot.

Enter a setting between 50 - 150%.

## The Field icon

From the guidance screen, tap  to create a new field or select an existing field. See [Chapter 9, Mapping and Guidance](#).

## The Guidance icon

From the guidance screen, tap  to quickly nudge, shift, or resume a guidance line:



## The Mapping icon

From the guidance screen, tap  to quickly add or delete the following features:

- rock
- line
- tree
- area
- weed
- exclusion

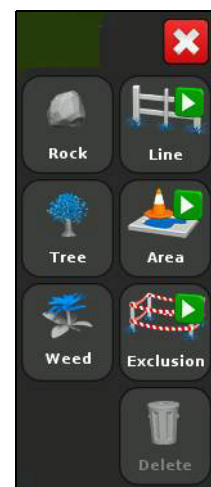

## The Auto steer icon

From the guidance screen, tap  to quickly adjust the aggressiveness setting for the EZ-Steer or Autopilot system:



## Reading lightbar patterns

When lit, the LEDs show the position of your vehicle relative to your intended guidance line. As your vehicle position changes in relation to the guidance line, the LEDs move left or right.



Use the lightbar to obtain accurate guidance when:

- you have set an implement offset or implement draft

- fine-tuning guidance on straight swaths

The LEDs in the integrated lightbar show the position of your vehicle relative to the guidance line:

- When your vehicle is on the guidance line, the three central green LEDs are lit.
- As your vehicle moves off the guidance line, the lit LEDs move left or right, and change to red. Note that the LED pattern that appears has a different meaning for each Main Lightbar LED Mode. For more information, see the table below, and [Lightbar Setup, page 210](#).

This LED pattern ...	Indicates that the vehicle is ...
	Directly on the guidance line.
	Off the guidance line. For this pattern, if the Main Lightbar LED Mode is set to: <ul style="list-style-type: none"> <li>• <b>Chase</b>, the vehicle is offline to the <i>left</i>.</li> <li>• <b>Pull</b>, the vehicle is offline to the <i>right</i>.</li> </ul>
	Off the guidance line. For this pattern, if the Main Lightbar LED Mode is set to: <ul style="list-style-type: none"> <li>• <b>Chase</b>, the vehicle is offline to the <i>right</i>.</li> <li>• <b>Pull</b>, the vehicle is offline to the <i>left</i>.</li> </ul>

## Using the EZ-Remote joystick

Optionally, you can use an EZ-Remote™ joystick to control the FM-750 display. The joystick has ten LED buttons: six have preset functions; you can assign one of the following functions to each of the other four:

- Map a rock, tree, or weed
- Start or finish a line
- Start or finish an area
- Start or finish an exclusion zone
- Turn coverage on or off
- Camera A or Camera B control
- Show trailing map view
- Show overhead map view
- Zoom
- Show status

To learn how to assign a function to a programmable button, see [EZ-Remote joystick, page 212](#).









## On-screen icons









The tables in this section describe all of the icons available on the FM-750 display.

**Note** – Icons appear only when they are appropriate. They are not visible at all times.



To activate an icon, tap it with your finger. If the display does not respond when you tap it, see [Recalibrate touchscreen](#), page 221.



## System icons

Icon	Description
	System and display setup
	Autopilot setup
	GPS/GLONASS setup
	Data configuration
	Help
	Settings / Configuration
	Next page
	Back page



Icon	Description
	Menu
	Configure
	Status
	Setup wizard
	Edit item
	Delete
	Cancel changes
	Accept / save changes



## Information icons

Icon	Description
	Setup complete
	Critical warning



Icon	Description
	General alert
	Information



### View icons

Icon	Description
	Activate external video input
	Full screen external video
	Run screen trailing view







Icon	Description
	Zoom in
	Zoom out
	Run screen overhead view







### Application icons

Icon	Description
	Manual section control
	Automatic section control
	Target rate



Icon	Description
	Section control off
	Coverage logging on
	Coverage logging off



### Guidance icons

Icon	Description
	Guidance pattern select
	Pause guidance
	Nudge left
	Nudge right
	Record FreeForm guidance pattern
	Set A point



Icon	Description
	Start recording headland
	Pause recording headland
	End headland recording
	Cannot engage auto guidance
	Ready to engage auto guidance
	Auto guidance engaged





Icon	Description
	Set B point
	Shift AB line
	Next AB line

Icon	Description
	Increase auto guidance aggressiveness
	Decrease auto guidance aggressiveness

### Mapping icons

Icon	Description
	Map line feature
	Map tree (point feature)
	Map rock (point feature)

Icon	Description
	Mapping configuration
	Area feature

# Vehicle

## In this chapter:

- [Introduction](#)
- [The EZ-Steer assisted steering system](#)
- [The EZ-Pilot steering system](#)
- [The Autopilot automated steering system](#)

This chapter describes how to configure your auto steer system for use with the FM-750 display.

## Introduction

To ensure the correct performance of your auto steer system, you must calibrate it correctly. Before you calibrate your auto steer option, do the following:

- Ensure that the vehicle's hydraulic oil is up to operating temperature. Refer to the vehicle documentation.
- Ensure that the tire pressure is correct.
- Complete the GPS Setup on the FM-750 display. For more information, see [Chapter 10, GPS](#).

When you calibrate your auto steer option, pay attention to the following:

- Choose a field with the smoothest possible surface and perform the calibration at the normal operating speed for the vehicle.
- For a high-clearance sprayer, perform the initial calibration without an implement or with the booms folded in. After the initial calibration is completed, you can fine tune the settings with the implement or booms folded out.

The calibration process requires a straight AB line. If you do not create an AB line before you begin the calibration, the system prompts you to open a field and create one.

To access the auto steer options:

1. In the guidance screen, tap  and then tap **Vehicle**.
2. Tap **Auto Steer**:

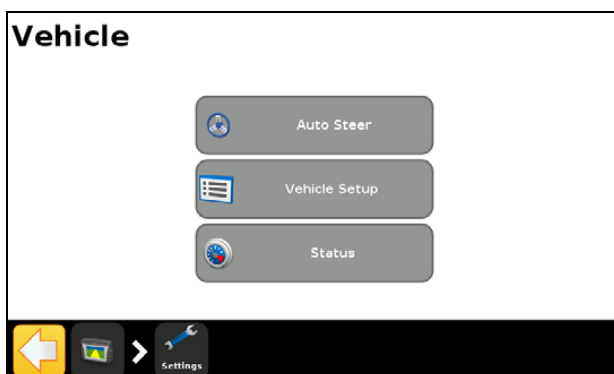

## The EZ-Steer assisted steering system

The EZ-Steer assisted steering system works with the FM-750 display's internal GPS receiver to provide vehicle guidance. As such, you must complete the GPS setup before you calibrate, set up, or run your EZ-Steer system. See [Chapter 10, GPS](#).

### Setup

To view and adjust the settings for the EZ-Steer system:

1. In the guidance screen, tap  and then tap **Vehicle**.
2. Tap **Auto Steer** and then **EZ-Steer Setup**:

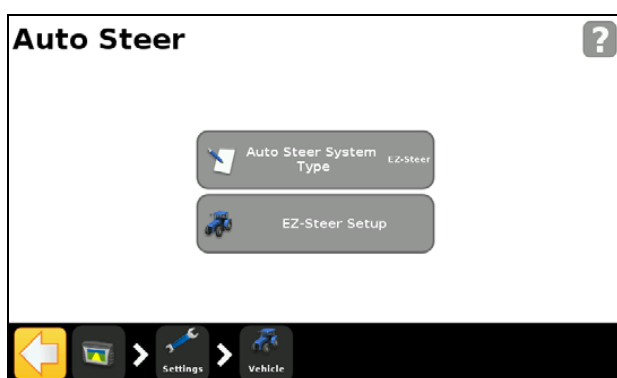

**Note** – If the **EZ-Steer Setup** button does not appear, tap **Auto Steer System Type** and then select **EZ-Steer** for your controller.

The EZ-Steer Setup screen contains the following options:

- Engage Options
- Vehicle Setup
- Aggressiveness
- EZ-Steer Demo
- EZ-Steer Calibration Wizard

The following sections describe each option.

### Engage Options

Use this option to view and adjust the settings described below:

Setting ...	Notes ...
Minimum/Maximum speed	Enter the minimum and maximum speeds at which the EZ-Steer system will disengage: <ul style="list-style-type: none"> <li>• <b>Minimum:</b> between 1.0 and 15.9 mph (1.6 and 25.5 kph).</li> <li>• <b>Maximum:</b> between 1.0 and 18.0 mph (1.6 and 28.8 kph).</li> </ul>

Setting ...	Notes ...
Maximum Angle	The EZ-Steer system will not engage when the vehicle is heading toward the guidance line at an angle greater than the Maximum Angle. Enter an angle between 5 and 45 degrees.
Engage/Disengage Offline	<ul style="list-style-type: none"> <li>Engage offline: The system will not engage when the vehicle is offline further than the Engage Offline distance. Enter a distance between 0' 5" and 27' 0" (0.2 and 8.2 m).</li> <li>Disengage offline: The system will automatically disengage when the vehicle is offline further than the Disengage Offline distance. Enter a distance between 0' 6" and 27' 00" (0.2 m and 8.2 m).</li> </ul>
Override sensitivity	Control how much force is required to disengage the system. Enter an increment between 1-100%.
EZ-Steer external switch	Enable or disable additional safety features.
EZ-Steer operator timeout	Enter a time between 1-60 minutes.

## Vehicle Setup

Use this option to view and adjust the settings described below:

Setting ...	Notes ...
Vehicle type	Enter the type of vehicle on which the EZ-Steer system will be installed.
Wheelbase	See <a href="#">Entering vehicle measurements, page 47</a> .
Antenna height	See <a href="#">Entering vehicle measurements, page 47</a> .
Antenna to axle offset	See <a href="#">Entering vehicle measurements, page 47</a> .
Angle per turn	Adjust the angle that the wheels turn during one full rotation of the steering wheel. Enter an angle between 2-149 degrees.
Freeplay left/right	Adjust this setting if the vehicle is consistently off to the right or left of the guidance line. Enter a measurement of 0-12" (0-30.48 cm).
Motor speed	Control the speed of the EZ-Steer drive wheel motor.
Motor direction is reversed	Select yes or no.
Sprayer steering delay	Account for time lags with vehicle steering. Enter a value between 0.1-1.5.
Swather steering delay	Account for time lags with vehicle steering. Enter a value between 0.1-1.5.

## Aggressiveness

Use this option to view and adjust the settings described below:

Setting ...	Notes ...
Online aggressiveness	Control how aggressively the EZ-Steer system corrects deviations from the guidance line. Enter a value between 50-150%.
Approach aggressiveness	Control how fast the EZ-Steer system steers the vehicle onto the guidance line. Enter a value between 50-150%

## EZ-Steer Demo

Use this option to access the EZ-Steer Demo Mode.

EZ-Steer Demo Mode is useful for practice with defining fields, coverage logging, and assisted steering. EZ-Steer Demo Mode requires an EZ-Steer controller, motor, and EZ-Steer simulator stand (P/N 54836-00).

## EZ-Steer Calibration Wizard

The EZ-Steer Calibration Wizard guides you through the process of calibrating your EZ-Steer system.

## Calibration

Before you begin to use the display you must calibrate the EZ-Steer system. To do this, complete the Quick Start Wizard (see [The Quick Start Wizard, page 29](#)) that appears the first time that you use the display.

**Note** – *You must have GPS connected.*

To calibrate the EZ-Steer system at a later time, complete the following process:

1. In the guidance screen, tap  and then tap **Vehicle**.
2. Tap **Auto Steer** and then tap **EZ-Steer Setup**:



**Note** – If the EZ-Steer Setup button does not appear, tap Auto Steer System Type and then select EZ-Steer for your controller.

3. In the EZ-Steer Setup screen, tap **EZ-Steer Calibration Wizard**.

- The wizard guides you through the following processes:
- Entering your vehicle measurements
- T2<sup>®</sup> roll calibration
- EZ-Steer calibration

## Entering vehicle measurements

For optimum guidance, you must take accurate vehicle measurements and enter them into the display.



**Note** – Do not enter calibration numbers from EZ-Guide<sup>®</sup> Plus or EZ-Steer<sup>®</sup> T2 systems. This may cause very poor vehicle control, including swerves and/or large oscillations.

To streamline the calibration process, you may want to take the vehicle measurements and record them for entry later on.

The techniques for taking vehicle measurements are described below; to learn about implement measurements, see [Implement Setup options, page 171](#).

Before you take the measurements, position your vehicle as follows:

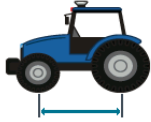
1. Park the vehicle on level ground.
2. Make sure that the vehicle is straight, with the centerline of the body parallel to the wheels.
3. Take the vehicle measurements:

To take this measurement ...	Measure from the ...	
Wheelbase	Center (the axle) of the front wheel to the center of the back wheel. Note that the wheelbase measurement for: <ul style="list-style-type: none"> <li>• <b>Tracked vehicles</b>, is exactly half of the length of the track</li> <li>• <b>Articulated 4WD vehicles</b>, is half of the distance between the center of the front and rear wheels.</li> </ul>	
Antenna height	Ground to the top of the GPS antenna.	

To take this measurement ...	Measure from the ...
Antenna to axle offset	<p>Center (the axle) of the front or rear wheel to the top of the GPS antenna.</p> <p><b>Note</b> – Make sure that you take this measurement to within 7.6 cm (3 in.) as an incorrect distance may result in poor steering performance.</p> <p>Take the measurement from the antenna to the correct point of your vehicle, as follows:</p> <ul style="list-style-type: none"> <li>• <b>Rear axle:</b> <ul style="list-style-type: none"> <li>- MFWD</li> <li>- Sprayer</li> <li>- Floater</li> <li>- Truck</li> </ul> </li> <li>• <b>Front axle:</b> <ul style="list-style-type: none"> <li>- 4wd tractor</li> <li>- Combine</li> </ul> </li> <li>• <b>Track center:</b> <ul style="list-style-type: none"> <li>- Tracked tractor</li> </ul> </li> </ul> <p>If the antenna is:</p> <ul style="list-style-type: none"> <li>• in <b>front</b> of the axle, enter a <b>Forward</b> distance</li> <li>• <b>behind</b> the axle, enter a <b>Behind</b> distance</li> </ul>





## T2 roll calibration

Calibrating the T2 roll sensor enables the display to calibrate terrain compensation in the EZ-Steer controller. This step requires you to:

- Enter an accurate value for controller orientation.
- Park the vehicle and mark the inside of both sets of wheels.
- Remain stationary while the system calculates the roll offset. This takes approximately 20 seconds.
- Turn the vehicle around and ensure the wheels are over the positions marked in the previous step.
- Remain stationary while the system calculates the roll offset. This takes approximately 20 seconds.

## EZ-Steer calibration

In this step you must drive and engage on a straight AB line in a clear field:

1. Begin driving and then tap .
2. Drive 160 feet and then tap .

A series of calibration screens will allow you to adjust any settings as necessary.



## Operation

You must calibrate and set up the EZ-Steer system before operation.

### Engaging the system

Before you can engage the EZ-Steer system, you must:

- open a field in the guidance screen
- define an AB line
- position the vehicle within the configured engage limits

To engage the system:

1. Point the nose of the vehicle toward the guidance line and drive at operational speed.
2. Do one of the following:
  - From the guidance screen, tap  .
  - Press the optional remote engage foot pedal.



### Disengaging the system

The EZ-Steer system automatically disengages when one of the following happens:

- The vehicle is outside the configured engage limits.
- You pause the system.
- GPS positions are lost.
- You tap the **Engage** button on the guidance screen.

You can manually disengage the EZ-Steer system by turning the steering wheel (this overrides the electric motor). Check this setting before you start using the system by engaging on a line and then turning the wheel until the system disengages. To adjust the amount of force required to disengage the system, change the *Override Sensitivity* in the *Engage Options* screen.

## Engage status indicators

Engage status	Icon color
Ready to engage	
Engaged	
Cannot engage	

## Curve Auto steering Accuracy in Headlands

It is possible to engage the EZ-Steer system on headlands with sharp corners at the edge of the field. However, the EZ-Steer system may be unable to drive around these sharp bends. Use one of the following methods to compensate:

- Manually steer the vehicle around the corner. Once you have rounded the corner, re-engage the EZ-Steer system.
- In the Engage Options screen, increase the Disengage Offline distance.

## Vehicle-specific performance

Before you use the EZ-Steer system, consider the following performance suggestions.

Vehicle type	Performance hint
2WD tractor	<p>With tractors that have SuperSteer (for example, New Holland TG), if the tractor has a SuperSteer front axle, for best performance:</p> <ul style="list-style-type: none"> <li>• Reduce the Online Aggressiveness value.</li> <li>• Line up close to the swath and make certain that the front wheels are straight before engaging the EZ-Steer system.</li> <li>• To get smoother performance when the vehicle is pulling an implement over tilled ground, enable the Diff-Lock. This prevents the machine from pulling sharply to the left or right. If you are calibrating on a hard surface, turn off Diff-Lock.</li> </ul>
4WD tractor	<p>The EZ-Steer system can be installed on Case IH STX tractors with Accusteer. For optimal performance, disable Accusteer using the switch in the cab (if possible).</p>
Sprayer	<ul style="list-style-type: none"> <li>• It is common for these vehicles to have slow steering. To compensate for this, use high aggressiveness.</li> <li>• If you experience large, slow oscillations, increase the aggressiveness.</li> <li>• When you configure the system on a sprayer, the Sprayer steering delay setting is available on the <i>Vehicle Setup</i> screen.</li> <li>• Some sprayers have steering that is slow to react after you turn the steering wheel. The system uses the steering delay setting to compensate for this slowness and ensure that steering corrections occur at the correct point.</li> </ul>

Vehicle type	Performance hint
Swather	<ul style="list-style-type: none"> <li>• When you configure the system on a swather, the Swather steering delay setting is available on the Vehicle Setup screen.</li> <li>• Some swathers have steering that is slow to react after the steering wheel is turned. The system uses the steering delay setting to compensate for this slowness and ensure that steering corrections occur at the correct point.</li> <li>• To improve the performance of your swather, adjust the Swather steering delay setting by a small amount (0.1 seconds) at a time. Test the result between each adjustment</li> </ul>

### After using the EZ-Steer system

- Any time that you are not using the EZ-Steer system, pivot the EZ-Steer motor away from the steering wheel.
- **Before** you leave the vehicle turn off the EZ-Steer system power switch or remove the power plug.

## The EZ-Pilot steering system

The EZ-Pilot™ steering system works with the FM-750 display's internal GPS receiver to provide vehicle guidance. You must therefore complete the GPS setup before you calibrate, set up, or run your EZ-Pilot system. See [Chapter 10, GPS](#).

### Setup

To view and adjust the settings for the EZ-Pilot system:

1. In the guidance screen, tap  and then tap **Vehicle**.
2. Tap **Auto Steer** and then **EZ-Pilot Setup**:

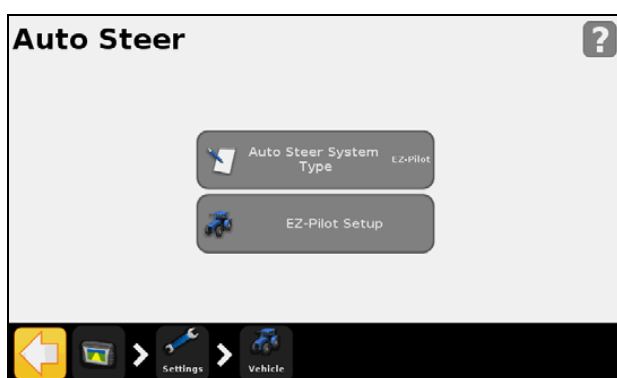

**Note** – If the EZ-Pilot Setup button does not appear, tap Auto Steer System Type and then select EZ-Pilot for your controller.

The EZ-Pilot Setup screen contains the following options:

- Engage Options
- Vehicle Setup
- Aggressiveness
- Vehicle Calibration menu

The following sections describe each option.

### Engage Options

Use this option to view and adjust the settings described below:

Setting ...	Notes ...
Minimum/Maximum speed	Enter the minimum and maximum speeds at which the EZ-Pilot system will disengage: <ul style="list-style-type: none"> <li>• <b>Minimum:</b> between 1.0 and 15.9 mph (1.6 and 25.5 kph).</li> <li>• <b>Maximum:</b> between 1.0 and 18.0 mph (1.6 and 28.8 kph).</li> </ul>

Setting ...	Notes ...
Maximum Angle	The EZ-Pilot system will not engage when the vehicle is heading toward the guidance line at an angle greater than the Maximum Angle. Enter an angle between 5 and 45 degrees.
Engage/Disengage Offline	Engage offline: The system will not engage when the vehicle is offline further than the Engage Offline distance. Enter a distance between 0' 5" and 27' 0" (0.2 and 8.2 m). Disengage offline: The system will automatically disengage when the vehicle is offline further than the Disengage Offline distance. Enter a distance between 0' 6" and 27' 00" (0.2 m and 8.2 m).
Override sensitivity	Control how much force is required to disengage the system. Enter an increment between 1-100%.
Operator timeout	Enter a time between 1-60 minutes.

## Vehicle Setup

Use this option to view and adjust the settings described below:

Setting ...	Notes ...
Vehicle type	Enter the type of vehicle on which the EZ-Pilot system will be installed.
Wheelbase	See <a href="#">Entering vehicle measurements, page 54</a> .
Antenna height	
Antenna to axle offset	
Freeplay left / right	Drives consistently to one side of the line. <ul style="list-style-type: none"> <li>• If the vehicle is offline to the left, increase the Freeplay offset to the right.</li> <li>• If the vehicle is offline to the right, increase the Freeplay offset to the left.</li> </ul>
Motor speed	Control the speed of the EZ-Pilot drive wheel motor.

## Aggressiveness

Use this option to view and adjust the settings described below:

Setting ...	Notes ...
Online aggressiveness	Control how aggressively the EZ-Pilot system corrects deviations from the guidance line. Enter a value between 50-150%.
Approach aggressiveness	Control how fast the EZ-Pilot system steers the vehicle onto the guidance line. Enter a value between 50-150%

## Vehicle Calibration Menu

See [Angle Per Turn calibration, page 56](#)

## Calibration

Before you begin to use the display, you must calibrate the EZ-Pilot system. To do this, complete the Quick Start Wizard (see [The Quick Start Wizard, page 29](#)), that appears the first time that you use the display.

**Note** – *You must have GPS connected.*

To calibrate the EZ-Pilot system at a later time, complete the following process:

1. In the guidance screen, tap  and then tap **Vehicle**.
2. Tap **Auto Steer** and then **EZ-Pilot Setup**:



**Note** – *If the EZ-Pilot Setup button does not appear, tap Auto Steer System Type and then select EZ-Pilot for your controller.*

3. In the EZ-Pilot Setup screen, tap **EZ-Pilot Calibration Wizard**.

The wizard guides you through the following processes:

- Entering your vehicle measurements
- T3™ roll calibration
- EZ-Pilot calibration

### Entering vehicle measurements

For optimum guidance, you must take accurate vehicle measurements and enter them into the display.

**Note** – *Do not enter calibration numbers from EZ-Guide® Plus or EZ-Steer systems. This may cause very poor vehicle control, including swerves and/or large oscillations.*



To streamline the calibration process, you may want to take the vehicle measurements and record them for entry later on.

The techniques for taking vehicle measurements are described below; to learn about implement measurements, see [Implement Setup options, page 171](#).

Before you take the measurements, position your vehicle as follows:

1. Park the vehicle on level ground.
2. Make sure that the vehicle is straight, with the centerline of the body parallel to the wheels.

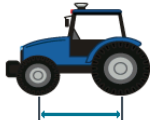
Take the vehicle measurements:

To take this measurement ...	Measure from the ...	
Wheelbase	Center (the axle) of the front wheel to the center of the back wheel. Note that the wheelbase measurement for <b>tracked vehicles</b> is exactly half of the length of the track.	
Antenna height	Ground to the top of the GNSS antenna.	
Antenna to axle offset	Center (the axle) of the front or rear wheel to the top of the GPS antenna. <b>Note</b> – Make sure that you take this measurement to within 7.6 cm (3 in.) as an incorrect distance may result in poor steering performance. Take the measurement from the antenna to the correct point of your vehicle, as follows: <ul style="list-style-type: none"> <li>• <b>Rear axle:</b> <ul style="list-style-type: none"> <li>- MFWD</li> <li>- Sprayer</li> <li>- Floater</li> <li>- Truck</li> </ul> </li> <li>• <b>Front axle:</b> <ul style="list-style-type: none"> <li>- 4wd tractor</li> <li>- Combine</li> <li>- Swathers</li> </ul> </li> </ul> <b>Note</b> – For swathers, it is recommended that you put the antenna directly above the front axle or slight ahead. <ul style="list-style-type: none"> <li>• <b>Track center:</b> <ul style="list-style-type: none"> <li>- Tracked tractor</li> </ul> </li> </ul> If the antenna is: <ul style="list-style-type: none"> <li>• in <b>front</b> of the axle, enter a <b>Forward</b> distance</li> <li>• <b>behind</b> the axle, enter a <b>Behind</b> distance</li> </ul>	

## T3 roll calibration

Calibrating the T3 roll sensor enables the display to calibrate terrain compensation in the IMD-600 unit. This step requires you to:

1. Enter an accurate value for the IMD-600 orientation:

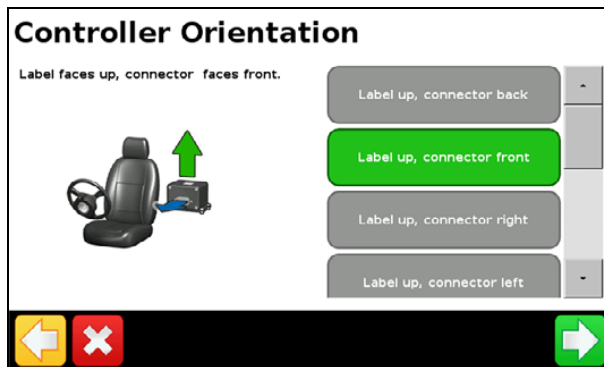

2. Park the vehicle and mark the inside of both sets of wheels.
3. Remain stationary while the system calculates the roll offset. This takes approximately 20 seconds.
4. Turn the vehicle around and ensure the wheels are over the positions marked in the previous step.
5. Remain stationary while the system calculates the roll offset. This takes approximately 20 seconds.

## Angle Per Turn calibration

You must first set the IMD-600 orientation and perform the T3 terrain compensation calibration.

You must operate the vehicle in an open field with ample area for the vehicle to make right and left turns.



1. Tap **Right Angle-Per-Turn Calibration**.
2. Drive forward until  appears and then tap the icon.

**Note** – For the best results drive the vehicle between 2 and 4 mph.

3. Allow the system to operate for 20 seconds until you receive a message that the calibration is complete.
4. Repeat [Step 1](#) through [Step 3](#) for left angle-per-turn calibration.

## EZ-Pilot system calibration

In this step you must drive and engage on a straight AB line in a clear field:

1. Begin driving and tap .
2. Drive 160 feet and then tap .



A series of calibration screens will allow you to adjust any settings as necessary.

## Operation

You must calibrate and set up the EZ-Pilot system before operation.



---

**CAUTION** – Do not operate the EZ-Pilot system while driving in reverse gear.

---

### Engaging the system

Before you can engage the EZ-Pilot system, you must:

- Open a field in the guidance screen
- Define an AB line
- Position the vehicle within the configured engage limits

To engage the system:

1. Point the nose of the vehicle toward the guidance line and drive at operational speed.
2. From the guidance screen or the optional remote control, tap  .



---

**CAUTION** – If you use the vehicle on a public roadway, you **must** put the red EZ-Pilot system override switch in the off position.

---

To engage the EZ-Pilot system, do one of the following:

- Tap **Engage** on the Run screen
- Press the **Engage** button on the EZ-Remote joystick, see [EZ-Remote joystick, page 212](#)
- Use an external foot or rocker switch, see [Engaging the EZ-Pilot system using an external foot or rocker switch, page 58](#)

## Engaging the EZ-Pilot system using an external foot or rocker switch

To install a foot or rocker switch:

1. Locate the foot or momentary rocker switch and the remote engage adapter cable (P/N 88506 - included with the foot switch kit, P/N 78150-00, or purchased separately).
2. Remove the wedge from a receptacle 3-pin Deutsch DTM:



3. Do one of the following:
  - For a foot switch, hold the receptacle with the lock facing upward with the black wire on the right-hand side, the white wire in the middle, and the green wire on the left-hand side:



**Note** – If you purchased P/N 78150-00, the correct connector is already attached.

- For a rocker switch, insert the wires into the right and middle sockets—the orientation does not matter:

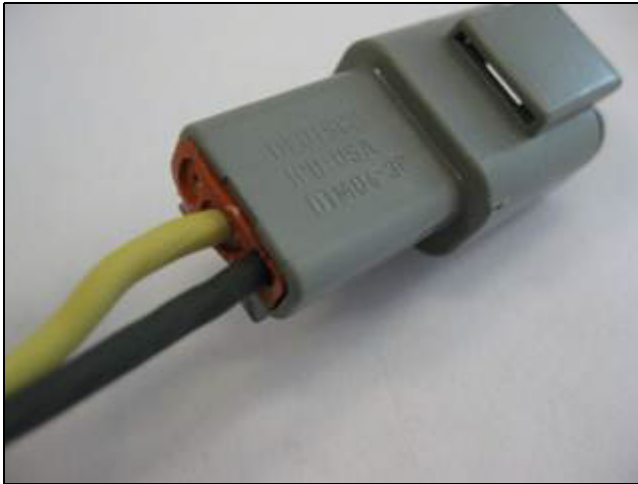

4. Re-insert the wedge into the receptacle:



5. Connect the attached receptacle to the 3-pin DTM plug on the remote engage adapter cable:

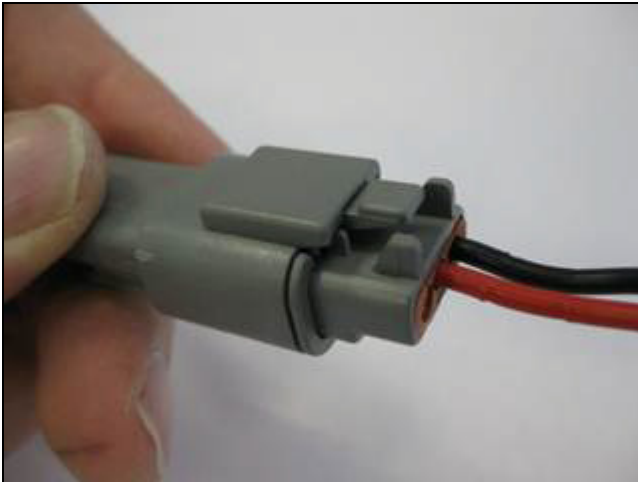

6. Plug the other end of the remote engage adapter cable into the port replicator (pin 10 and pin 11) on the EZ-Pilot cable that is connected to Port B on the FM-750 display:

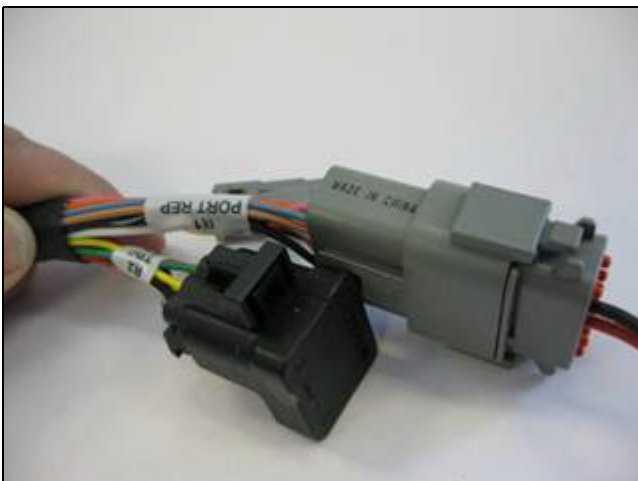

**Note** – If you are using a sonalert, you must remove engage pin 10 and move it to pin 8 so that the remote engage functions run between pin 8 and pin 11 and the sonalert functions between pin 2 and pin 10.

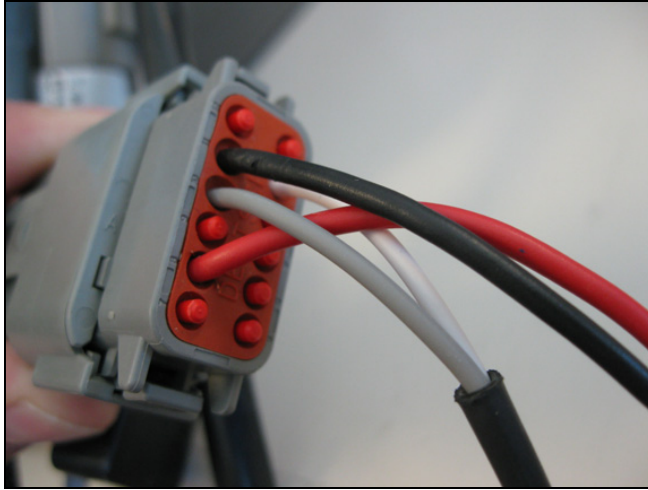

7. Route the cables of the footswitch or rocker switch to the required location:

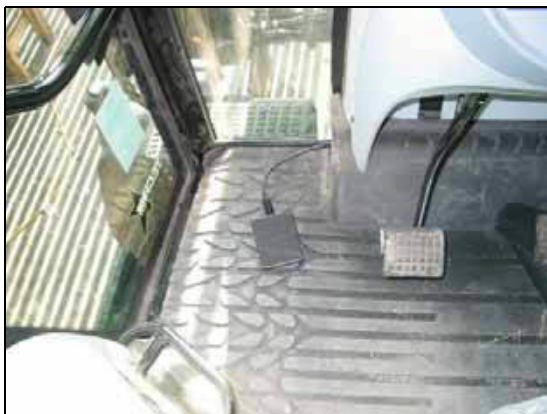

## Setting up the display when using a foot or rocket switch

1. Select *Settings / Vehicle / Auto Steer / EZ-Pilot Setup*.
2. Tap **EZ-Pilot External Switch**:

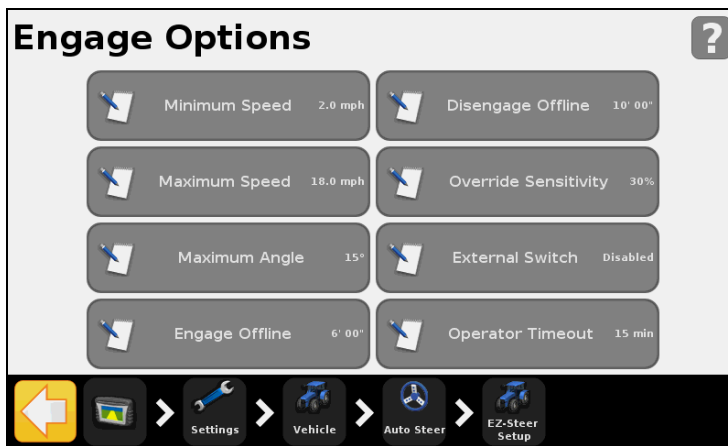

3. Tap **Remote Engage** and then tap :

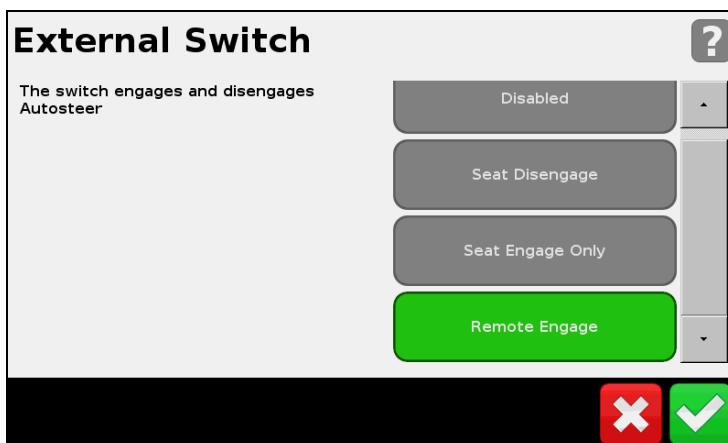

The Switch functionality now shows *Remote Engage* and is ready to be used:

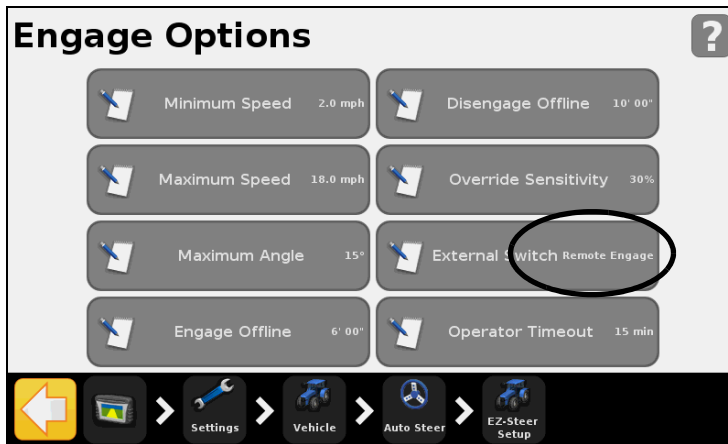



## Disengaging the system

The EZ-Pilot system automatically disengages when one of the following happens:

- The vehicle is outside the configured engage limits.
- You pause the system.
- GPS positions are lost.
- You tap the **Engage** button on the guidance screen.
- You press the **Engage** button on the optional EZ-Remote joystick.

You can manually disengage the EZ-Pilot system by turning the steering wheel (this overrides the electric motor). Check this setting before you start using the system by engaging on a line and then turning the wheel until the system disengages. To adjust the amount of force required to disengage the system, change the *Override Sensitivity* in the *Engage Options* screen.

## Engage status indicators

Engage status	Icon color
Ready to engage	
Engaged	
Cannot engage	

## Curve auto steering accuracy in headlands

It is possible to engage the EZ-Pilot system on headlands with sharp corners at the edge of the field. However, the EZ-Pilot system may be unable to drive around these sharp bends. Use one of the following methods to compensate:

- Manually steer the vehicle around the corner and then re-engage the EZ-Pilot system.
- In the *Engage Options* screen, increase the Disengage Offline distance.

## Vehicle-specific performance

Before you use the EZ-Pilot system, consider the following performance suggestions.

Vehicle type	Performance hint
2WD tractor	<p>With tractors that have SuperSteer (for example, New Holland TG), if the tractor has a SuperSteer front axle, for best performance:</p> <ul style="list-style-type: none"> <li>• Reduce the Online Aggressiveness value.</li> <li>• Line up close to the swath and make certain that the front wheels are straight before engaging the EZ-Pilot system.</li> <li>• To get smoother performance when the vehicle is pulling an implement over tilled ground, enable the Diff-Lock. This prevents the machine from pulling sharply to the left or right. If you are calibrating on a hard surface, turn off Diff-Lock.</li> </ul>
4WD tractor	<p>The EZ-Pilot system can be installed on Case IH STX tractors with Accusteer. For optimal performance, disable Accusteer using the switch in the cab (if possible).</p>
Sprayer	<ul style="list-style-type: none"> <li>• It is common for these vehicles to have slow steering. To compensate for this, use high aggressiveness.</li> <li>• If you experience large, slow oscillations, increase the aggressiveness.</li> <li>• When you configure the system on a sprayer, the Sprayer steering delay setting is available on the <i>Vehicle Setup</i> screen.</li> <li>• Some sprayers have steering that is slow to react after you turn the steering wheel. The system uses the steering delay setting to compensate for this slowness and ensure that steering corrections occur at the correct point.</li> </ul>



Vehicle type	Performance hint
Swather	<ul style="list-style-type: none"> <li>• When you configure the system on a swather, the Swather steering delay setting is available on the Vehicle Setup screen.</li> <li>• Some swathers have steering that is slow to react after the steering wheel is turned. The system uses the steering delay setting to compensate for this slowness and ensure that steering corrections occur at the correct point.</li> <li>• To improve the performance of your swather, adjust the Swather steering delay setting by a small amount (0.1 seconds) at a time. Test the result between each adjustment</li> </ul>

### After using the EZ-Pilot system



**CAUTION** – *Before* you leave the vehicle, turn off the power to the display which will turn off the EZ-Pilot system power.



**CAUTION** – If you use the vehicle on a public roadway, you **must** put the red EZ-Pilot system override switch in the off position.

# The Autopilot automated steering system

**Note** – For advanced setup options contact your Reseller.

## Setup

To view and adjust settings for the Autopilot system:

1. In the guidance screen, tap  and then tap **Vehicle**.
2. Tap **Auto Steer** and then tap **Autopilot Configuration**:

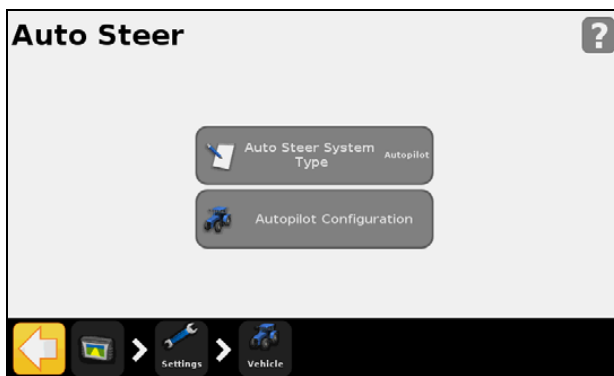

**Note** – If the *Autopilot Configuration* button does not appear, tap *Auto Steer System Type* and then select *Autopilot* for your controller.

From the *Autopilot Configuration* screen you can view and adjust the settings for:

- Online Aggressiveness
- Operator Alert Timeout
- End of Row Warning Distance
- NMEA Output. See [Chapter 10, GPS](#).
- Save Vehicle Configuration File (use a virtual keypad to save your current vehicle configuration)

## Operation

You must calibrate and set up the Autopilot automated steering system using AP Toolbox before operation.

### Engaging the system

Before you can engage the Autopilot automated steering system, you must:

- open a field in the guidance screen
- define an AB line
- position the vehicle within the configured engage limits

To engage the system:

1. Point the nose of the vehicle toward the guidance line and drive at operational speed.
2. Do one of the following:
  - From the guidance screen, tap .
  - Press the optional remote engage foot pedal.



## Disengaging the system

The Autopilot automated steering system automatically disengages when one of the following happens:

- The vehicle is outside the configured engage limits.
- You pause the system.
- GPS positions are lost.
- You tap the **Engage** button on the guidance screen.

You can manually disengage the system by turning the steering wheel (this overrides the electric motor). Check this setting before you start using the system by engaging on a line and then turning the wheel until the system disengages. To adjust the amount of force required to disengage the system, change the Override Sensitivity in the *Engage Options* screen.

## Engage status indicators

Engage status	Icon color
Ready to engage	
Engaged	
Cannot engage	

## After using the Autopilot automated steering system

**Before** you leave the vehicle turn off the system power switch or remove the power plug.

# Implement Application Controller

## In this chapter:

- [Introduction](#)
- [HARDI 5500 controller](#)
- [Raven controllers](#)
- [Rawson controller](#)
- [Amazone controller](#)
- [LH 5000 controller](#)
- [Vaderstad controller](#)
- [Bogballe controller](#)
- [Checking the implement connection](#)

This chapter describes how to configure the FM-750 display to use an implement application controller.

## Introduction

The options in the *Implement* screen enable you to configure an implement application controller, such as the Field-IQ crop input control system.

To access the *Implement* screen:

1. From the guidance screen, tap .
2. From the *Settings* screen, tap **Implement**:



The *Implement* screen contains two options, *Advanced* and *Initial Setup*. The *Advanced* option appears only after you have set up your controller using the *Initial Setup* option.

To set up your controller:

1. From the *Implement* screen, tap **Initial Setup**. The *Controller Type* screen appears.

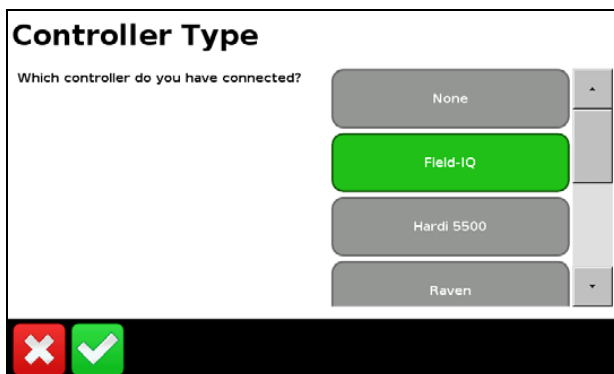

**Note** – To access all of the available *Controller Type* options (apart from *None* and *Field-IQ*) you must have a VRA unlock code. To obtain a VRA unlock code, contact your Reseller.

2. Select the controller that you are using.

**Note** – When you change the controller type, any open field will close.

3. Configure your controller. For more information, see:

- [HARDI 5500 controller, page 72](#)
- [Raven controllers, page 75](#)

- Rawson controller, page 79
- Amazone controller, page 83
- LH 5000 controller, page 86

## Prescriptions

The FM-750 display can use a prescription file to determine the rate of application in different areas of the field.

The prescription file consists of three separate ESRI files: .shp, .dbf and .shx. Each of these files contain different attribute information that the display uses.

You must load a prescription from the USB drive to the internal memory of the FM-750 display. The display cannot read prescriptions directly from a USB drive. For more information, see the section below.

### Loading a prescription

1. Copy the prescription file from your computer to the *AgGPS/Prescriptions* folder on your USB drive.

**Note** – If you do not have an AgGPS® directory on your USB, create one by exporting field data to the USB. For more information, see [Sending data to the USB drive, page 205](#).

2. Insert the USB drive into the USB socket, and then copy the prescription file to the display's internal memory. See [Retrieving data from the USB drive, page 205](#).
3. From the guidance screen, tap  to create a new field or select an existing field.

The FM-750 display searches the internal memory for prescription files, and after you define or select a field, the following screen appears in the wizard:

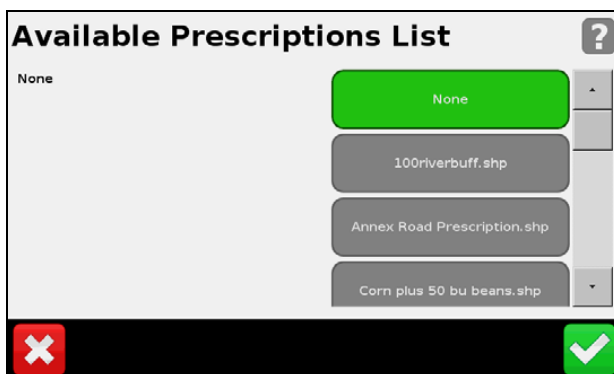

4. Select the prescription file that you require and then tap . The following screen appears:

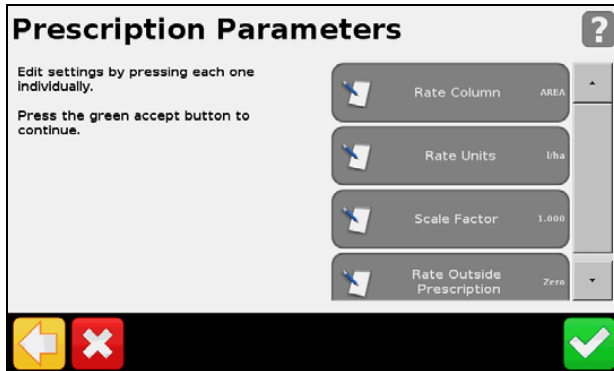

5. Configure each of the items in the *Prescription Parameters* screen.



**CAUTION** – For the system to work correctly, you **must** select the correct Rate Column setting. If you do not, then the applied rate will be incorrect.

## HARDI 5500 controller

**Note** – For the HARDI 5500 controller to work correctly with the FM-750 display, you must install firmware version 3.16 or greater on the HARDI controller and connect a JOBCOM control box.

### Setup

1. Once you select the HARDI 5500 as your controller, the following screen appears on the display:

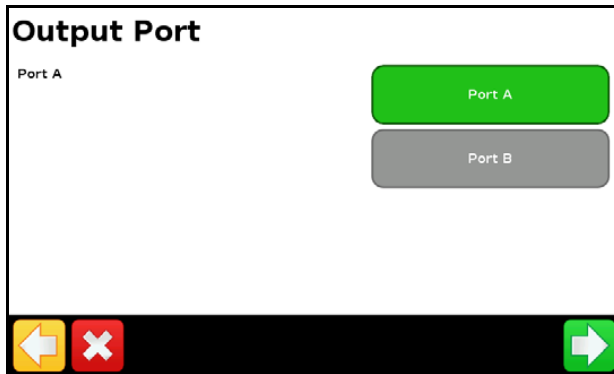

**Note** – Do not configure the display to output NMEA messages on the same port that your controller is connected to.

2. On the HARDI 5500 controller, go to the *Settings* menu.
3. Change Remote to Enable.

For more information on setting up the HARDI 5500 controller, refer to the HARDI instruction manual.

### Advanced

Use the *Advanced* option in the *Implement* screen to configure the following:

- Boom Setup
- Swath Control
- Rate Control
- Off When Stopped
- Rate Snapping



## Boom Setup

**Note** – The boom setup on the FM-750 display must match the setup on the HARDI controller. If the boom setup differs between the display and the HARDI controller, a warning message appears on the display.

Use this option to view and adjust the following settings:

Setting ...	Notes ...
Implement width	Enter a width between 1' 00" - 328' 01" (0.30 - 99.99 m).
Fence Nozzles	Enter the locations of any fence nozzles.
Number of sections	Enter a number between 1 - 10.

## Swath Control

Use this option to view and adjust the following settings:

Setting ...	Notes ...
Boom control	Enter a width between 1' 00" - 328' 01" (0.30 - 99.99 m).
Coverage switching overlap	Control the amount of boom switching overlap allowed before the section will be switched by the system. Enter a value between 1 - 99%.
Boundary switching overlap	Control the amount of overlap on a boundary before the boom section is switched off. Enter a value between 1 - 99%.
On/Off valve latency	Tune the section switching to allow for hardware delays. Enter a time between 0.0 - 10.0 seconds.
Intentional overlap	Set a distance to be overlapped when moving to an unsprayed area or out of a sprayed area. Enter a distance between 0' 00" - 32' 10" (0.00 - 10.00 m).

## Rate control

Use this option to view and adjust the following settings:

Setting ...	Notes ...
On	Application rates are sent from a prescription loaded in the display or the target rate manually configured on the display.
Off	The target rate must be set on the HARDI controller. The FM-750 display does not send target rates to the controller. This is the default setting.

**Note** – When sending a target rate to the HARDI 5500 controller that is higher than 99.9, the display rounds to the nearest whole number. For example, 0-99.9 is not rounded. 101.4 is rounded to 101.

## Off When Stopped

You can use this option to control whether the system allows the vehicle to continue operating when it is not moving.

If the vehicle is a clutch-operated planter, select No so you can continue planting even when stopped.

## Rate Snapping

Due to pump constraints, liquid flow is generally inconsistent. To control how these inconsistencies appear on your display, turn rate snapping on or off.

Value ...	Notes ...
On	Matches the applied rate to the target rate when within 10% of the value.
Off	Shows all fluctuations in the actual applied rate.

## Operation

When you connect the HARDI 5500 controller to the FM-750 display, the following items appear on the guidance screen:

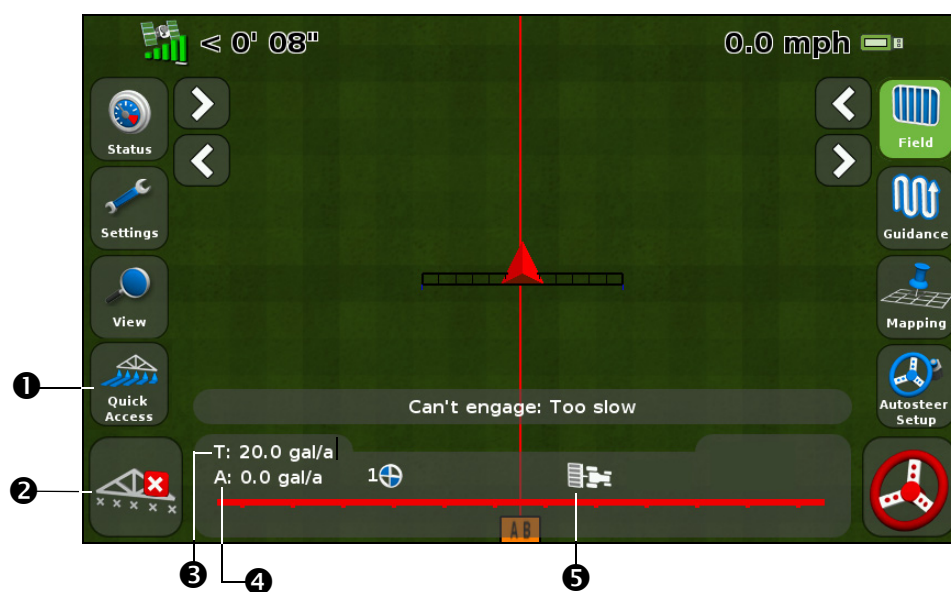

Item	Description	Notes
1	Quick Access icon	See, <a href="#">Quick Access icon</a> , page 34.

Item	Description	Notes
②	Boom section status indicators	Shows the current state of each boom section: <ul style="list-style-type: none"> <li>• Green: Enabled and spraying</li> <li>• Gray: Enabled but not currently spraying</li> <li>• Red: The section is off (the switch is off)</li> </ul>
③	Target rate	If a prescription is loaded, P displays to indicate that the prescription rate is being used rather than the target rate.
④	Actual rate	As the HARDI controller does not report the actual applied rate to the display, this item always appears as N/A.
⑤	Section control	Shows the current mode for the controller.
	Fence nozzle indicator	This indicator appears only when a fence nozzle is enabled. Fence nozzle status is represented with the same colors as the boom sections (see below).  <b>Note</b> – The FM-750 display cannot automatically turn fence nozzles on or off. It only displays the current status.
	Application indicator	The wheel on the display spins when the HARDI master switch is on and the booms are on.

## Raven controllers

When using the Raven SCS 400 and 600 series controller with the FM-750 display, note the following:

- The FM-750 display cannot control the status of the Raven controller master or boom switches. This means that the operator must remain in complete control of the sprayer at all times.
- The FM-750 display cannot automatically turn off the sprayer when going outside headlands, across exclusion zones, or previously sprayed areas.
- The sprayer may not always switch off completely when the FM-750 sends a zero rate. This means the operator may need to manually turn off the master switch to ensure that spray is not applied.

**Note** – The only time the FM-750 display sends a zero rate is when the sprayer is outside a prescription boundary and the "Rate outside polygon" option is zero.

- The operator must ensure that the master switch is off when there is no field open so that no spray is accidentally applied to areas that shouldn't be sprayed, for example, roads, paths, and neighboring fields.

## Setup

- Once you select Raven as your controller, the following screen appears on the display:

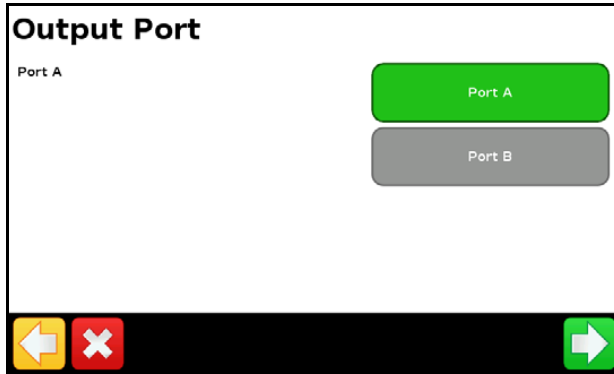

**Note** – Do not configure the display to output NMEA messages on the same port that your controller is connected to.

- On the Raven controller, configure the following Data Menu settings:

Item	Setting
Baud or Baud Rate	9600
GPS	Inac
DLOG or Data Log	On
TRIG or Data Log Trigger Value	1
UNITor Data Log Trigger Units	sec

**Note** – In the GPS group, if ‘Send time’, ‘Time acknowledge’ or ‘Close file’ appear, change them to GPS Inac. Otherwise, the DLOG or DATA LOG option will not appear.

For more information on configuring and calibrating the Raven controller, refer to the Raven instruction manual.

## Advanced

Use the *Advanced* option in the *Implement* screen to configure the following:

- Boom Setup
- Target Rate
- Rate Snapping

## Boom Setup

Use this option to view and adjust the following settings:

Setting ...	Notes ...
Implement width	Enter a width between 1' 00" - 328' 01" (0.30 - 99.99 m).
Number of sections	Enter a number between 1 - 10.

## Target Rate

Set the target application rate that will be sent to the Raven controller. Enter a rate between 0.0 - 11000.0.

## Rate Snapping

Due to pump constraints, liquid flow is generally inconsistent. To control how these inconsistencies appear on your display, turn rate snapping on or off.

Setting ...	Notes ...
On	Matches the applied rate to the target rate when within 10% of the value.
Off	Shows all fluctuations in the actual applied rate.

## Operation

When you connect the Raven controller to the FM-750 display, the following items appear on the guidance screen:

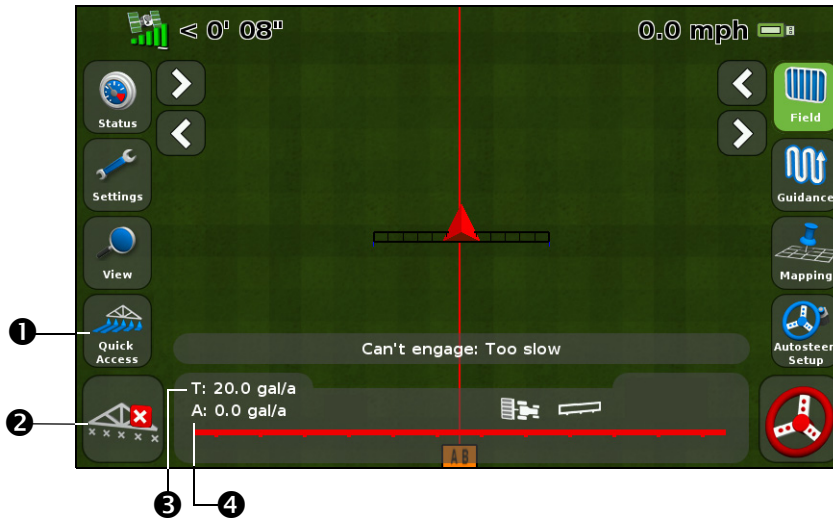

Item	Description	Notes
①	Quick Access icon	See <a href="#">Quick Access icon</a> , page 34.
②	Boom section status indicators	Shows the current state of each boom section: <ul style="list-style-type: none"> <li>• Green: Enabled and spraying</li> <li>• Gray: Enabled but not currently spraying</li> <li>• Red: The section is off (the switch is off)</li> </ul>
③	Target rate	If a prescription is loaded, P displays to indicate that the prescription rate is being used rather than the target rate.
④	Actual rate	The actual application rate. This is the amount of product that is currently being applied.
	Application indicator	The wheel on the display spins when the Raven master switch is on and the booms are on.

### Target Rate

To manually enter a rate to send to the controller:

1. In the **Settings** screen, tap **Implement** and then **Advanced**.
2. Tap **Target Rate** and then adjust the rate that is sent to the controller.

### Automatic Boom Switching

The FM-750 display will not do automatic boom switching for the Raven controller.

**Note** – To ensure that areas outside the headland, in exclusion zones, or previously sprayed areas are not sprayed, you will need to manually turn off the Raven controller master switch.

## Rawson controller

### Setup

1. Once you select Rawson as your controller, a warning message appears. Make sure that you read the message carefully, and then tap  to continue:

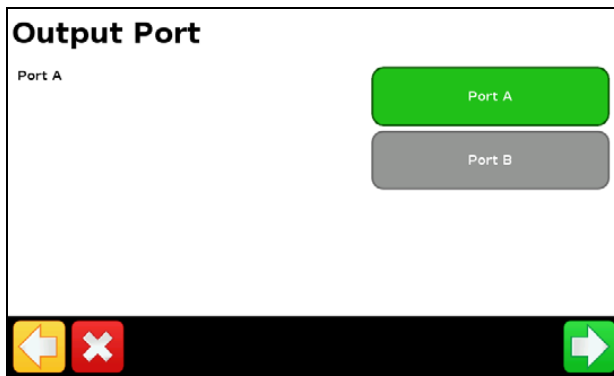

2. Change the Output Port to COM or AUX to match the port on the display that the controller is connected to.
3. On the Rawson controller:
  - Verify the default target rate and step size and then enter these values into the FM-750 display. To learn how to change these settings on the FM-750 display, see [Advanced](#), below.
  - Set the baud rate to 9600.

To enable the FM-750 display to change the rates on the controller, you must also set the Rawson controller to GPS mode:

1. Turn the Rawson controller on.
2. Press the MODE button twice.
3. Press the SET button to switch the controller between GPS and non-GPS modes.

**Note** – If you do not set the Rawson controller to use GPS mode, the FM-750 display will only log the rates being used.

For more information on configuring the Rawson controller, refer to the *ACCU-RATE Controller 9.2A User Guide*.

### Advanced

Use the *Advanced* option in the *Implement* screen to configure the following:

- Boom Setup
- Swath Control
- Target Rate
- Default Rate
- Step Size
- Rate Snapping

## Boom Setup

Use this option to view and adjust the following settings:

Setting ...	Notes ...
Implement width	Enter a width between 1' 00" - 328' 01" (0.30 - 99.99 m).
Number of sections	Enter a number between 1 - 10.

## Swath Control

Use this option to view and adjust the following settings:

Setting ...	Notes ...
Boom control	Enter a width between 1' 00" - 328' 01" (0.30 - 99.99 m).
Coverage switching overlap	Control the amount of boom switching overlap allowed before the section will be switched by the system. Enter a value between 1 - 99%.
Boundary switching overlap	Control the amount of overlap on a boundary before the boom section is switched off. Enter a value between 1 - 99%.
On/Off valve latency	Tune the section switching to allow for hardware delays. Enter a time between 0.0 - 10.0 seconds.
Intentional overlap	Set a distance to be overlapped when moving to an unsprayed area or out of a sprayed area. Enter a distance between 0' 00" - 32' 10" (0.00 - 10.00 m).

## Target Rate

Set the target application rate that will be sent to the Rawson controller. Enter a rate between 0.0 - 11000.0.

Alternatively, you can load a prescription so the FM-750 display will automatically send target rates to the Rawson controller.

**Note** – When the FM-750 display is sending target rates to the Rawson controller, the Rawson controller will only display the Target Rate screen. To change or view any other screen on the Rawson controller, you must unplug the FM-750 display cable.



**Note** – When using a prescription with the Rawson controller, the target rates in the prescription must match the step sizes in the Rawson controller. For example, if the default is 25000 and the step size is 4%, then the target rate values accepted by the Rawson controller are 26000, 27000, 28000...40000. Otherwise, the Rawson controller may not be able to apply the correct rate.

## Default Rate

On the FM-750 display, set the same target rate that appears on the Rawson controller when you first power up it up. Enter a number between 0 - 9999000.

## Step Size

The step size increases or decreases the actual applied rate by the percentage that you select. You can choose from one of the following settings:

- 2%
- 4%
- 6 <sup>2</sup>/<sub>3</sub>%

## Rate Snapping

Due to pump constraints, liquid flow is generally inconsistent. To control how these inconsistencies appear on your display, turn rate snapping on or off.

Setting ...	Notes ...
On	Matches the actual applied rate to the target rate when within 10% of the value.
Off	Shows all fluctuations in the actual applied rate.

## Operation

When you connect the Rawson controller to the display, the following items appear on the FM-750 guidance screen:

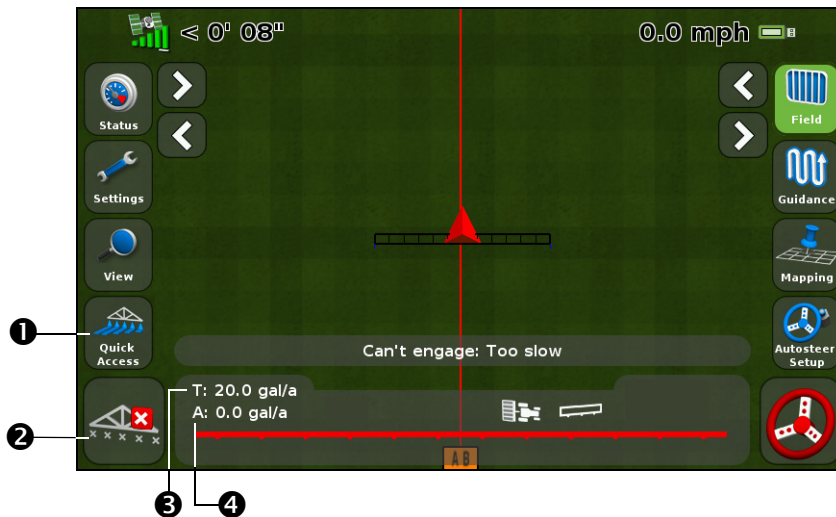

Item	Description	Notes
1	Quick Access icon	See <a href="#">Quick Access icon</a> , page 34.
2	Boom section status indicators	Shows the current state of each boom section: <ul style="list-style-type: none"> <li>Green: Enabled and spraying</li> <li>Gray: Enabled but not currently spraying</li> <li>Red: The section is off (the switch is off)</li> </ul>
3	Target rate	If a prescription is loaded, P displays to indicate that the prescription rate is being used rather than the target rate.
4	Actual rate	The actual application rate. This is the amount of product that is currently being applied.
	Application indicator	The wheel on the display spins when the Rawson master switch is on and the lightbar receives flow messages from the controller.

# Amazone controller

## Setup

1. Once you select Amazone as your controller, the following screen appears on the display:

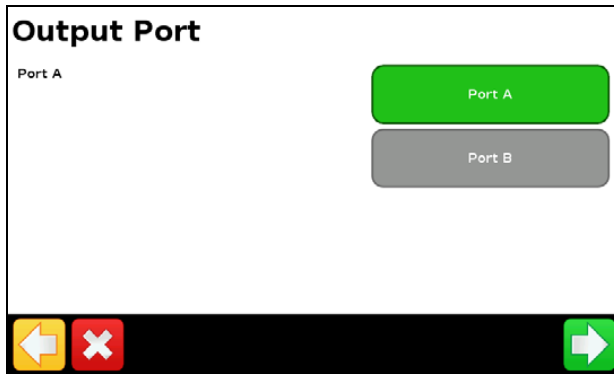

**Note** – Do not configure the display to output NMEA messages on the same port that your controller is connected to.

2. On the Amazone controller, go to the *Settings* menu.
3. Change Remote to Enable.

For more information on setting up the Amazone controller, refer to the Amazone instruction manual.

## Advanced

Use the *Advanced* option in the *Implement* screen to configure the following:

- Boom Setup
- Swath Control
- Rate Control
- Target Rate
- Turn Off Rate on Overlap
- Rate Snapping

## Boom Setup

**Note** – The boom setup on the FM-750 display must match the setup on the Amazone controller. If the boom setup differs between the display and the Amazone controller, a warning message appears on the display.

Use this option to view and adjust the following settings:

Settings ...	Notes ...
Implement width	Enter a width between 1' 00" - 328' 01" (0.30 - 99.99 m).
Fence Nozzles	Enter the locations of any fence nozzles.
Number of sections	Enter a number between 1 - 10.

## Swath Control

Use this option to view and adjust the following settings:

Settings ...	Notes ...
Boom control	Enter a width between 1' 00" - 328' 01" (0.30 - 99.99 m).
Coverage switching overlap	Control the amount of boom switching overlap allowed before the section will be switched by the system. Enter a value between 1 - 99%.
Boundary switching overlap	Control the amount of overlap on a boundary before the boom section is switched off. Enter a value between 1 - 99%.
On/Off valve latency	Tune the section switching to allow for hardware delays. Enter a time between 0.0 - 10.0 seconds.
Intentional overlap	Set a distance to be overlapped when moving to an unsprayed area or out of a sprayed area. Enter a distance between 0' 00" - 32' 10" (0.00 - 10.00 m).

## Rate control

Use this option to view and adjust the following settings:

Settings ...	Notes ...
On	Application rates are sent from a prescription loaded in the display or the target rate manually configured on the display.
Off	The target rate must be set on the Amazone controller. The FM-750 display does not send target rates to the controller. This is the default setting.

**Note** – When sending a target rate to the Amazone controller that is higher than 99.9, the display rounds to the nearest whole number. For example, 0-99.9 is not rounded. 101.4 is rounded to 101.

## Target Rate

Set the target application rate that will be sent to the Amazone controller. Enter a rate between 0.0 - 11000.0.

## Turn Off Rate on Overlap

Use this option to view and adjust the following settings:

Settings ...	Notes ...
Yes	Does not spray over an area that has been previously sprayed.
No	Sprays over an area that has been previously sprayed.

## Operation

When you connect the Amazone controller to the display, the following items appear on the display's guidance screen:

Item	Notes
Actual rate	
Target rate	If a prescription is loaded, P displays to indicate that the prescription rate is being used rather than the target rate.
Boom section status indicators	Shows the current state of each boom section: <ul style="list-style-type: none"> <li>• Green: Enabled and spraying</li> <li>• Gray: Enabled but not currently spraying</li> <li>• Red: The section is off (the switch is off)</li> </ul>
Application indicator	The wheel on the display spins when the Amazone master switch is on and the lightbar receives flow messages from the controller.
Quick Access icon	See <a href="#">Quick Access icon</a> , page 34.

# LH 5000 controller

## Setup

1. Once you select the LH5000 as your controller, the following screen appears on the display:

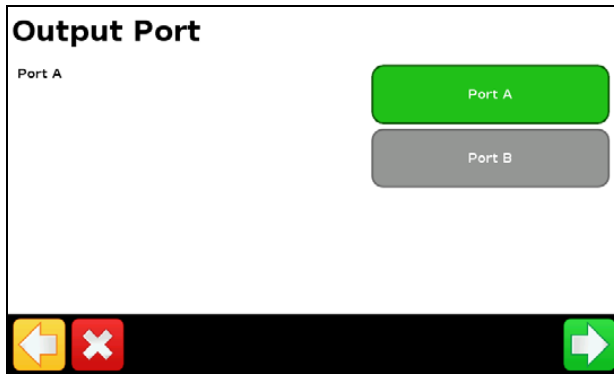

2. On the FM-750 display, make sure that Output Port matches the port on the display that the controller is connected to (COM or AUX).
3. Do not configure the display to output NMEA messages on the same port that your controller is connected to.

For more information on configuring the LH 5000 controller, refer to the LH 5000 instruction manual.

## Advanced

Use the *Advanced* option in the *Implement* screen to configure the following:

- Boom Setup
- Swath Control
- Rate Control
- Target Rate
- Turn Off Rate on Overlap
- Rate Snapping

### Boom Setup

**Note** – The boom setup on the FM-750 display must match the setup on the LH 5000 controller. If the boom setup differs between the display and the LH 5000 controller, a warning message appears on the display.

Use this option to view and adjust the following settings:

Setting ...	Notes ...
Implement width	Enter a width between 1' 00" - 328' 01" (0.30 - 99.99 m).
Fence Nozzles	Enter the locations of any fence nozzles.
Number of sections	Enter a number between 1 - 10.

## Swath Control

Use this option to view and adjust the following settings:

Setting ...	Notes ...
Boom control	Enter a width between 1' 00" - 328' 01" (0.30 - 99.99 m).
Coverage switching overlap	Control the amount of boom switching overlap allowed before the section will be switched by the system. Enter a value between 1 - 99%.
Boundary switching overlap	Control the amount of overlap on a boundary before the boom section is switched off. Enter a value between 1 - 99%.
On/Off valve latency	Tune the section switching to allow for hardware delays. Enter a time between 0.0 - 10.0 seconds.
Intentional overlap	Set a distance to be overlapped when moving to an unsprayed area or out of a sprayed area. Enter a distance between 0' 00" - 32' 10" (0.00 - 10.00 m).

## Rate control

Use this option to view and adjust the following settings:

Setting ...	Notes ...
On	Application rates are sent from a prescription loaded in the display or the target rate manually configured on the display.
Off	The target rate must be set on the LH 5000 controller. The FM-750 display does not send target rates to the controller. This is the default setting.

**Note** – When sending a target rate to the LH 5000 controller that is higher than 99.9, the display rounds to the nearest whole number. For example, 0-99.9 is not rounded. 101.4 is rounded to 101.

## Target Rate

Set the target application rate that will be sent to the LH 5000 controller. Enter a rate between 0.0 - 11000.0.

## Turn Off Rate on Overlap

Use this option to view and adjust the following settings:

Setting ...	Notes ...
Yes	Does not spray over an area that has been previously sprayed.
No	Sprays over an area that has been previously sprayed.

## Operation

When the LH 5000 variable rate controller is connected to the display, the following items appear on the FM-750 display's guidance screen:

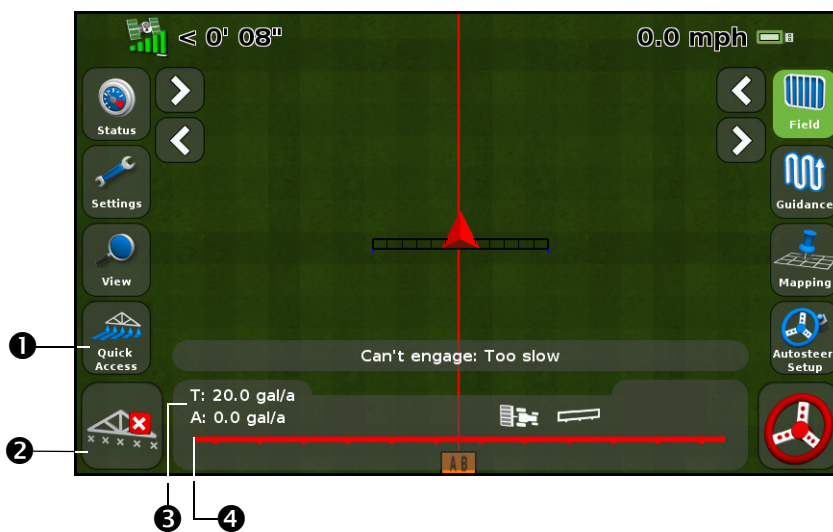

Item	Description	Notes
❶	Quick Access icon	See <a href="#">Quick Access icon</a> , page 34.
❷	Boom section status indicators	Shows the current state of each boom section: <ul style="list-style-type: none"> <li>Green: Enabled and spraying</li> <li>Gray: Enabled but not currently spraying</li> <li>Red: The section is off (the switch is off)</li> </ul>
❸	Target rate	If a prescription is loaded, P displays to indicate that the prescription rate is being used rather than the target rate.
❹	Actual rate	The actual application rate. This is the amount of product that is currently being applied.
	Application indicator	The wheel on the display spins when the LH 5000 master switch is on and the lightbar receives flow messages from the controller.



# Vaderstad controller

## Setup

1. Once you select Vaderstad as your controller, the following screen appears on the display:

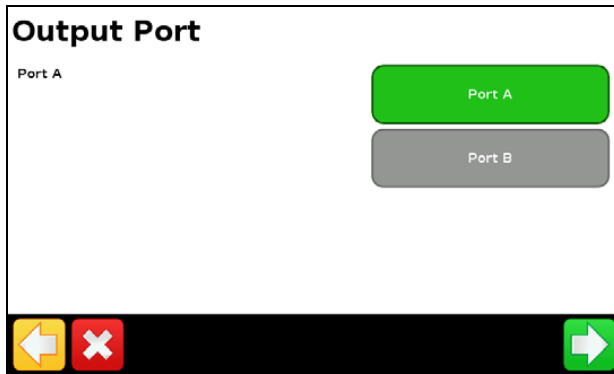

**Note** – Do not configure the display to output NMEA messages on the same port that your controller is connected to.

2. In the Device Type screen, select the type of implement you are using:
  - Sprayer
  - Planter/Seeder
  - Fertilizer/Spreader
3. On the Vaderstad controller, go to the setup screen.
4. Set GPS to No.

## Advanced

Use the Advanced option in the Implement screen to configure the following:

- Boom Setup
- Swath Control
- Rate Control
- Target Rate
- Single section boom switching
- Rate Snapping

## Boom Setup

**Note** – The boom setup on the FM-750 display must match the setup on the LH 5000 controller. If the boom setup differs between the display and the LH 5000 controller, a warning message appears on the display.

Use this option to view and adjust the following settings:

Setting ...	Notes ...
Implement width	Enter a width between 1' 00" - 328' 01" (0.30 - 99.99 m).
Fence Nozzles	Enter the locations of any fence nozzles.
Number of sections	Enter a number between 1 - 10.

## Swath Control

Use this option to view and adjust the following settings:

Setting ...	Notes ...
Boom control	Enter a width between 1' 00" - 328' 01" (0.30 - 99.99 m).
Coverage switching overlap	Control the amount of boom switching overlap allowed before the section will be switched by the system. Enter a value between 1 - 99%.
Boundary switching overlap	Control the amount of overlap on a boundary before the boom section is switched off. Enter a value between 1 - 99%.
On/Off valve latency	Tune the section switching to allow for hardware delays. Enter a time between 0.0 - 10.0 seconds.
Intentional overlap	Set a distance to be overlapped when moving to an unsprayed area or out of a sprayed area. Enter a distance between 0' 00" - 32' 10" (0.00 - 10.00 m).

## Rate control

Use this option to view and adjust the following settings:

Setting ...	Notes ...
On	Application rates are sent from a prescription loaded in the display or the target rate manually configured on the display.
Off	The target rate must be set on the LH 5000 controller. The FM-750 display does not send target rates to the controller. This is the default setting.

**Note** – When sending a target rate to the LH 5000 controller that is higher than 99.9, the display rounds to the nearest whole number. For example, 0-99.9 is not rounded. 101.4 is rounded to 101.

## Target Rate

Set the target application rate that will be sent to the LH 5000 controller. Enter a rate between 0.0 - 11000.0.

## Single section boom switching

Use this to turn off the implement in areas that have already been applied.

**Note** – *This setting can only turn the entire boom on and off. It does not support individual sections.*

- Select Yes to avoid spraying an area that has previously been sprayed.
- Select No to spray an area that has previously been sprayed.

## Rate Snapping

Due to pump constraints, liquid flow is generally inconsistent. To control how these inconsistencies appear on your display, turn rate snapping on or off.

Value ...	Notes ...
On	Matches the applied rate to the target rate when within 10% of the value.
Off	Shows all fluctuations in the actual applied rate.

## Bogballe controller

The FM-750 display is compatible with Bogballe Calibrator ZURF, ICON, and UNIQ controllers.

## Setup

1. Once you select Bogballe as your controller, the following screen appears on the display:

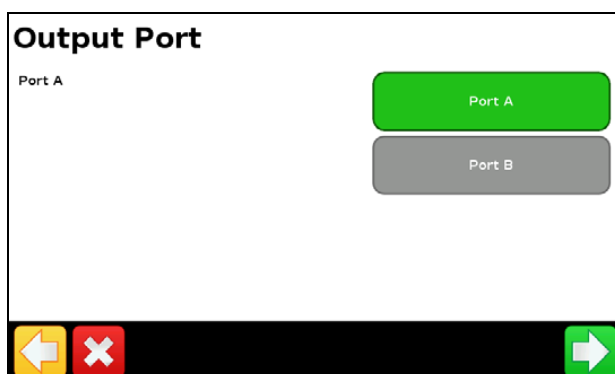

**Note** – *Do not configure the display to output NMEA messages on the same port that your controller is connected to.*

- On the Bogballe controller, press Return / Return / Fertil.-Distrib / Select Type / Bogballe E/EX / Accept

For more information on setting up the Bogballe controller, refer to the Bogballe instruction manual.

## Advanced

Use the Advanced option in the Implement screen to configure the following:

- Boom Setup
- Swath Control
- Rate Control
- Target Rate
- Single Section Boom Switching

### Boom Setup

**Note** – The boom setup on the FM-750 display must match the setup on the LH 5000 controller. If the boom setup differs between the display and the LH 5000 controller, a warning message appears on the display.

Use this option to view and adjust the following settings:

Setting ...	Notes ...
Implement width	Enter a width between 1' 00" - 328' 01" (0.30 - 99.99 m).
Fence Nozzles	Enter the locations of any fence nozzles.
Number of sections	Enter a number between 1 - 10.

### Swath Control

Use this option to view and adjust the following settings:

Setting ...	Notes ...
Boom control	Enter a width between 1' 00" - 328' 01" (0.30 - 99.99 m).
Coverage switching overlap	Control the amount of boom switching overlap allowed before the section will be switched by the system. Enter a value between 1 - 99%.
Boundary switching overlap	Control the amount of overlap on a boundary before the boom section is switched off. Enter a value between 1 - 99%.
On/Off valve latency	Tune the section switching to allow for hardware delays. Enter a time between 0.0 - 10.0 seconds.
Intentional overlap	Set a distance to be overlapped when moving to an unsprayed area or out of a sprayed area. Enter a distance between 0' 00" - 32' 10" (0.00 - 10.00 m).

## Rate control

Use this option to view and adjust the following settings:

Setting ...	Notes ...
On	Application rates are sent from a prescription loaded in the display or the target rate manually configured on the display.
Off	The target rate must be set on the LH 5000 controller. The FM-750 display does not send target rates to the controller. This is the default setting.

**Note** – When sending a target rate to the LH 5000 controller that is higher than 99.9, the display rounds to the nearest whole number. For example, 0-99.9 is not rounded. 101.4 is rounded to 101.

## Target Rate

Set the target application rate that will be sent to the LH 5000 controller. Enter a rate between 0.0 - 11000.0.

## Single section boom switching

Use this to turn off the implement in areas that have already been applied.

**Note** – This setting can only turn the entire boom on and off. It does not support individual sections.

- Select Yes to avoid spraying an area that has previously been sprayed.
- Select No to spray an area that has previously been sprayed.

## Checking the implement connection

To check that the FM-750 display and your implement controller are communicating correctly, access the *VR Controller Status* screen:

1. In the *Settings* screen, tap **Vehicle** and then tap **Status**.
2. Tap **VR Controller Status**. A screen similar to the following appears:

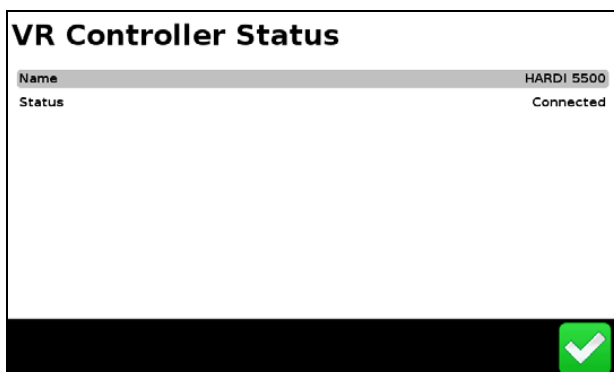

3. Check that the status displays *Connected*.

**Note** – *If the status displays Not Connected, verify that the controller cable is securely connected to the display. If the cable is secure, verify that the display and the controller are configured correctly, as detailed in the sections above.*

# Field-IQ Crop Input Control System

## In this chapter:

- [Overview](#)
- [Installing the Field-IQ hardware](#)
- [Setting up the Field-IQ system](#)
- [Operation](#)

The Field-IQ crop input control system enables the FM-750 display to control the following:

- planters
- sprayers
- liquid strip-till toolbars
- spinner spreaders

Additionally, it enables the display to use the Tru Count Air Clutch® or Tru Count LiquiBlock™ valves to perform automatic section control, and/or use a prescription with Rawson® drives to control seed or liquid fertilizer rates.

## Overview

The different functions of the Field-IQ system that you can configure and control are:

Application	Main functions
Planter	<ul style="list-style-type: none"> <li>Seed section control of up to 48 individual rows (Field-IQ section control module(s) needed) using the Tru Count Air Clutch.</li> <li>Seed rate control using up to 4 Rawson drives to change seed population (Field-IQ Rawson Control Module(s) needed).</li> <li>Seed rate control using up to 4 PWM drives to change seed population.</li> <li>Liquid fertilizer control of up to 48 individual liquid nozzles (Field-IQ section control module(s) needed) using Tru Count LiquiBlock valves.</li> </ul>
Sprayer	<ul style="list-style-type: none"> <li>Liquid section control of up to 48 individual rows (Field-IQ section control module(s) needed) using existing boom shutoff valves or Tru Count LiquiBlock valves.</li> <li>Connects to spraying systems that are configured with servo, pump servo, PWM, bypass, dump and master valves.</li> </ul>
Strip-till (liquid)	<ul style="list-style-type: none"> <li>Liquid section control of up to 48 individual spray nozzles (Field-IQ Section Control Module(s) needed) using Tru Count LiquiBlock valves.</li> <li>Liquid rate control using up to 2 Rawson drives connected to <b>fixed displacement pumps</b>, such as CDS-John Blue piston pumps, to change liquid rate (Field-IQ Rawson Control Module(s) needed).</li> <li>Liquid rate control using either a PWM or Servo control valve and flow meter.</li> </ul>
Spreading	<ul style="list-style-type: none"> <li>Spreading rate control using a Rawson Drive (Field-IQ Rawson Control Module(s) needed).</li> <li>Spreading rate control using either a PWM or Servo control valve and application rate sensor.</li> </ul>

## Definitions

Term	Definition
Section	A number of rows or spray nozzles that are controlled by the Tru Count Air Clutch or Tru Count LiquiBlock valves, or boom valves. A section can have either a single row/nozzle or multiple rows/nozzles depending on how the system is set up.
Row	The individual row unit that material comes from on the implement. This can be controlled individually as a single row section, or as a group with other rows in a multiple row section.
Master Switch Box (MSB)	Master on/off/jump start, auto/manual switch, rate selection, and increment/decrement switch. See <a href="#">Field-IQ master switch box, page 125</a>
12 Section Switch Box (12SSB)	Required for section control. Manually control sections/rows. See <a href="#">Field-IQ 12-section switch box, page 126</a>
Section Control Module (SCM)	Controls 12 sections/rows per module with up to 4 modules (48 module sections / rows).



Term	Definition
Rate and Section Control Module (RSCM)	Controls 12 sections and application rate for spraying, spreading and NH <sub>3</sub> .
Rawson Control Module (RWCM)	Controls 1 Rawson variable rate drive per module with up to 4 modules.
Implement Switch	Included in planter, NH <sub>3</sub> and strip-till platform kits.

## Units of measure

Type	Unit	Symbol	Description
Seed	Metric	kS/ha	Thousands of seeds per hectare
	US/Imperial	kS/a	Thousands of seeds per acre
Granular seed	Metric	kg/ha	Kilograms of seed per hectare
	US/Imperial	lbs/a	Pounds of seed per acre
Liquid application	Metric	L/ha	Liters per hectare
	US/Imperial	Gal/a	Gallons per acre
Granular fertilizer	Metric	kg/ha	Kilograms of fertilizer per hectare
	US/Imperial	lbs/a	Pounds of fertilizer per acre
NH <sub>3</sub>	Metric	kg/NH <sub>3</sub>	Kilograms of anhydrous per hectare
	US/Imperial	lbs/NH <sub>3</sub>	Pounds of anhydrous per acre
	Metric	kg/N	Kilograms of nitrogen per hectare
	US/Imperial	lbs/N	Pounds of nitrogen per acre

## Installing the Field-IQ hardware



**WARNING** – Anhydrous ammonia (NH<sub>3</sub>) can cause severe burning, blindness, or death. Before you begin to operate or service equipment that contains NH<sub>3</sub>, carefully read and follow all safety instructions in [Working with anhydrous ammonia, page 7](#).

For information on installing the Field-IQ crop input control system on your implement, refer to:

- *Field-IQ Platform Installation Instructions*
- *Tru Count Air Clutch Installation Instructions*
- *Rawson Installation Instructions*

For the latest versions of these documents, go to [www.trimble.com/agriculture](http://www.trimble.com/agriculture).

# Setting up the Field-IQ system

## Setting up the Implement and Control type

1. In the guidance screen, tap .
2. In the *Settings* screen, tap **Implement**:

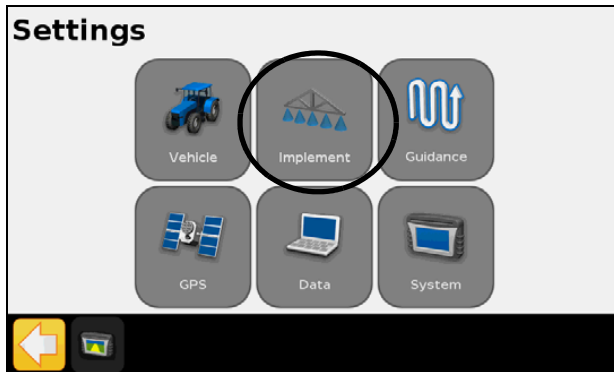

3. In the *Implement* screen, tap **Initial Setup**.

**Note** – When you are setting the system up for the first time, this is the only button that appears. However, if you have previously installed the Field-IQ system, more options will appear.

4. In the *Controller Type* screen, tap **Field-IQ** and then tap .

A *Summary* screen appears that shows all the Field-IQ components (with their serial numbers) detected by the display. To continue, tap .

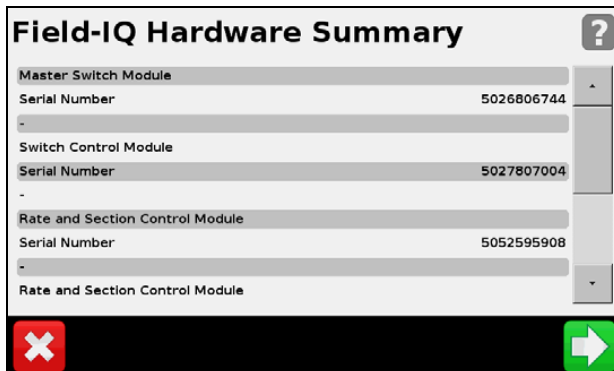

## Setting up the Implement Operation and Implement Layout

1. In the *Implement Type* screen, tap **Implement Operation**:

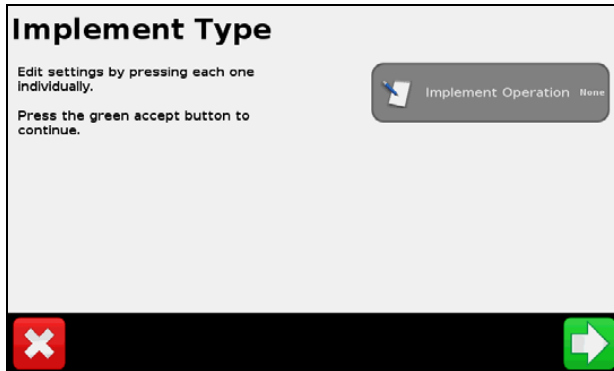

2. In the *Implement Operation* screen, tap the required operation and then tap :



3. In the *Implement Type* screen, tap **Implement Layout**.

The options that you can select depend on the operation you selected. The options are:

Implement operation	Implement layout options
Spreading	Pull-type spreader Spreader truck
Spraying	Front sprayer Rear sprayer Pull-type sprayer
Planting	Standard
Tillage	Tillage

4. Once you select both the Implement Operation and the Implement Layout, tap .

## Setting up the Implement Measurements

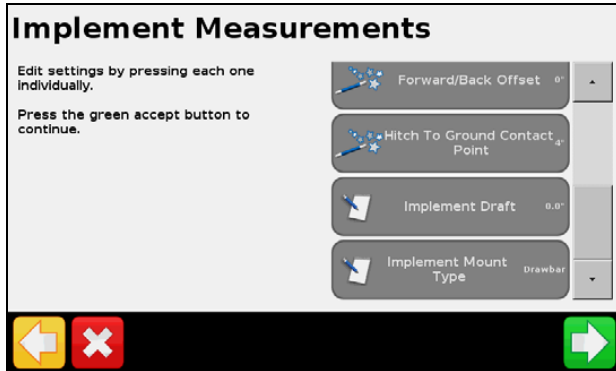

1. In the *Implement Measurements* screen, tap each option in turn to enter the measurements for your implement:



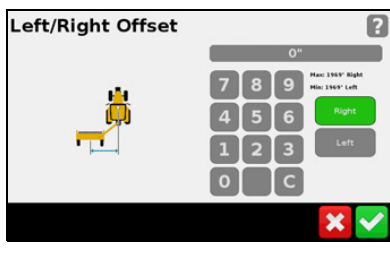
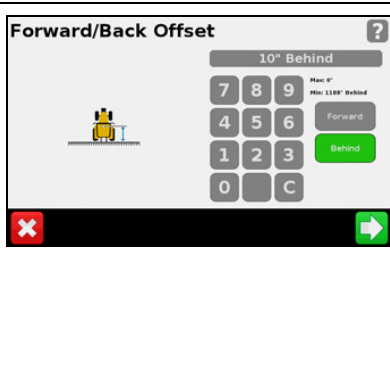

2. Once you enter the required measurements in a settings screen, tap  to return to the *Implement Measurement* screen and select the next option.

For the best performance, physically measure your implement and enter accurate values for each setting. The options are:

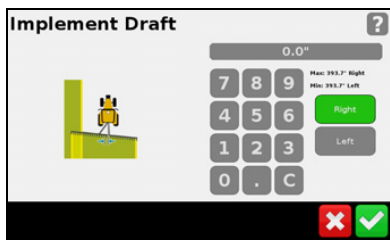
Tap	Description	
Number of Rows	Number of rows covered by the implement.	
Row Spacing	Spacing between the rows.	
Overlap / Skip	<p>The amount of overlap or skip between swaths.</p> <ul style="list-style-type: none"> <li>• Overlap is a intentional overlap between swaths to avoid any skips.</li> <li>• Skip is a intentional skip between swaths.</li> </ul> <p><b>Note</b> – This setting is used with the <i>Implement Width</i> to set the spacing of the swaths in the field.</p>	
Implement Width	<p>The width of the implement’s application coverage area. This measurement is used for coverage logging.</p> <ul style="list-style-type: none"> <li>• For planters this is calculated using the Number of Rows and the Row Spacing.</li> <li>• The swath spacing is calculated by the Implement Width and the Overlap/Skip setting.</li> </ul>	

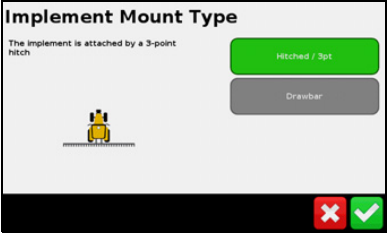
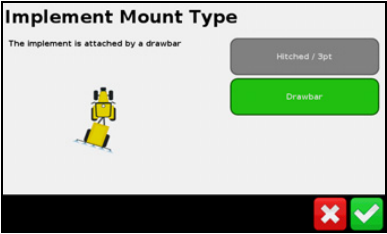
Tap	Description	
Left / Right Offset	<p>Used for implements that are offset to the left or right from the vehicle center line.</p> <p>This is measured from the center of the vehicle to the center of the implement.</p> <p>The measurement adjusts the tractor's path so that the implement is centered on the line.</p>	
Forward / Back Offset	<p>Used to reference the distance from the vehicle to the implement / application point.</p> <p>The offset is measured from the fixed axle of the vehicle to the point on the implement where coverage logging will be mapped.</p> <p>The fixed axle varies depending on vehicle type:</p> <ul style="list-style-type: none"> <li>• Rear axle on front steering tractors and self-propelled sprayers</li> <li>• Front axle on 4 x 4 articulated tractors</li> <li>• Center of tracks on tracked tractors</li> </ul>	
Hitch to Ground Contact Point	<p>Distance from the hitch to where the implement pivots on its ground contact point.</p> <p>Measured from the tractor's hitch pin to the soil engagement point that the implement rotates about.</p> <p>For planters this is typically the seeding units or the midpoint of several rows of tools.</p>	
Implement Draft	<p>Distance that the implement drifts away from the center line of the vehicle.</p> <p>This setting is used to adjust the implement back on line if the implement is physically drifting offline in the field.</p> <p><b>Note</b> – This setting is similar to the Left/Right Offset.</p>	

Tap	Description	
Implement Mount Type	<p>Select the required mount type:</p> <ul style="list-style-type: none"> <li>Hitched / 3pt: The implement is mounted on a 3-point hitch, which means that the implement rotates around the vehicle.</li> </ul> <p><b>Note</b> – When the vehicle makes a slight correction you will instantly see a change in the implement's location.</p> <ul style="list-style-type: none"> <li>Drawbar: The implement is attached by a drawbar, which means that the implement rotates around its ground contact point.</li> </ul> <p><b>Note</b> – When the vehicle makes a correction you may not see a change in the implement until a certain distance has been traveled.</p>	 

3. Once you enter all the required measurements, tap .

## Setting up the Implement Switches

1. In the *Implement Switches* screen, tap **Implement Lift Setup**:

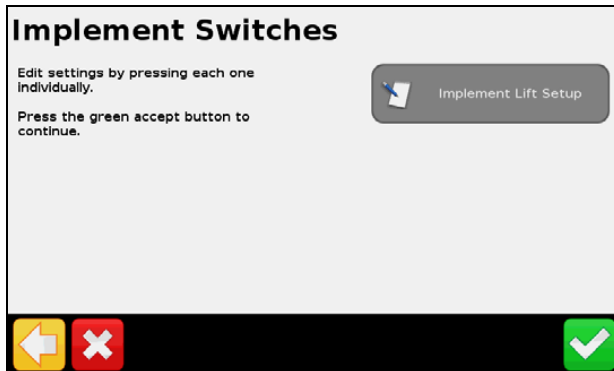

2. In the *Implement Lift Setup* screen, tap **Implement Lift Enable**, tap **Yes** in the *Implement Lift Enable* screen and then tap :

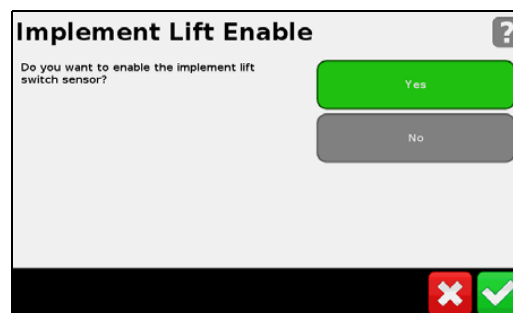
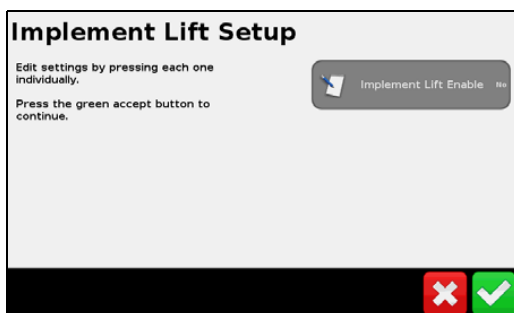

- You are returned to the *Implement Lift Setup* screen, where you can now set up the following:

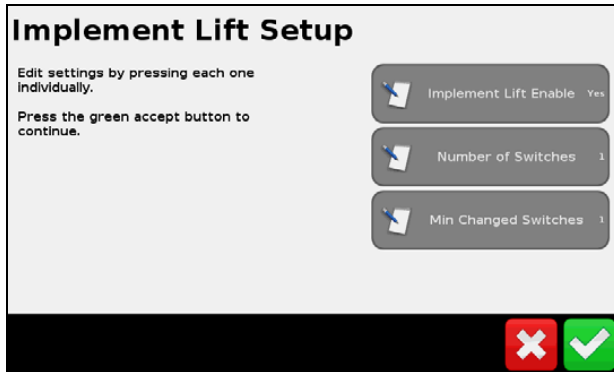

Tap	Description
Number of Switches	Number of implement switches hooked up to the Field-IQ system.
Min Changed Switches	Number of switch changes that are required to show the implement in a lifted state. For example, if three switches are hooked up to the Field-IQ system and this setting is set to two, the system must see two switches in the lifted position before the implement appears as lifted on the display.

- Tap  when done.

## Setting up a Material

- In the *Implement* screen, tap **Material Setup**:



- In the *Material Setup* screen, tap **New Material**.

3. In the *Material Management* screen, tap **Material Type**:

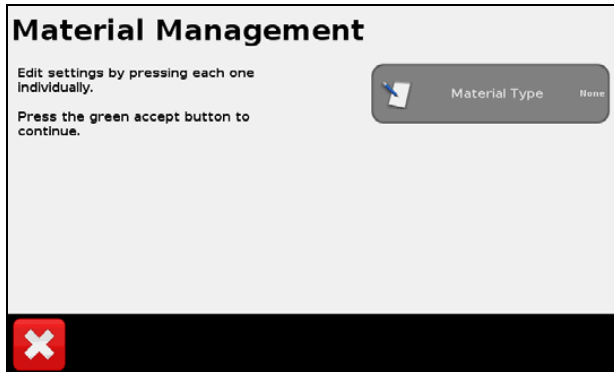

4. In the *Material Type* screen, select the material type you require:

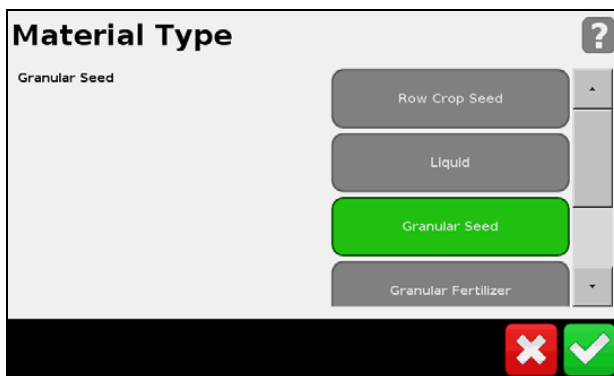

The options are:

- Row Crop Seed
  - Liquid
  - Granular Seed
  - Granular Fertilizer
  - Anhydrous
5. Once you make your selection, tap  to return to the *Material Management* screen.  
From this screen, you can now set up a specific material type.



## Setting up a Row Crop Seed in the Material Setup screen

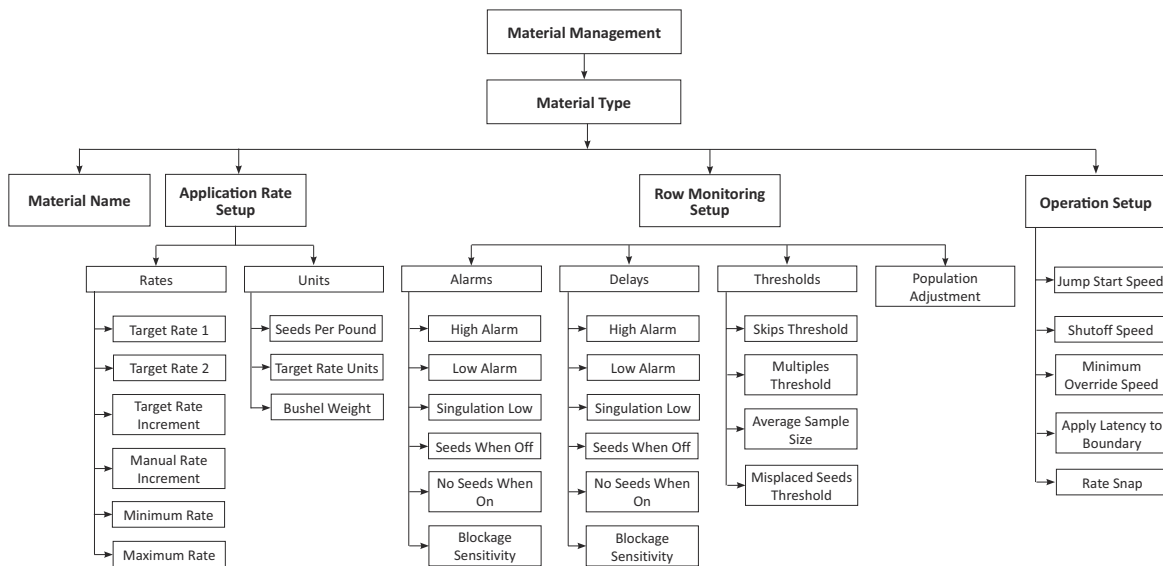

Once you select a *Material Type*, in the *Material Management* screen, tap **Material Name**, enter a name for the material and then tap

Once you have done this, the following options appear in the *Material Management* screen:

- Application Rate Setup
- Row Monitoring Setup
- Operation Setup

Select each option in turn and complete all settings for that option until you reach the final screen for that option—if you then tap , you are returned to the *Material Type* screen where you can select the next option.

The options are as follows:

Select ...	Options	Description
<b>Application Rate Setup: Rates</b> 	Target Rate 1	Preset rate for position 1 on the rate switch.
	Target Rate 2	Preset rate for position 2 on the rate switch.
	Target Rate Increment	Rate increase / decrease for Target Rate 1 or 2, when the Rate Adjustment Switch is clicked once.
	Manual Rate Increment	Valve movement when the Rate Adjustment Switch is used with the Rate Switch set to Manual.
	Minimum Rate	Minimum rate that will be applied with this material.
	Maximum Rate	Maximum rate that will be applied with this material.

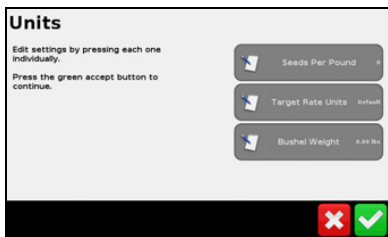
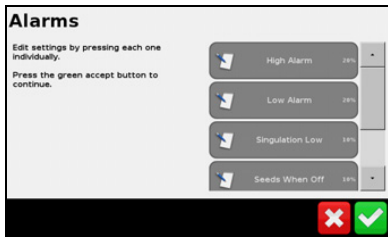
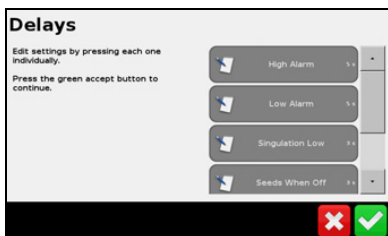
Select ...	Options	Description
<b>Application Rate Setup: Units</b>		
	Seeds Per Pound	Number of seeds per pound.
	Target Rate Units	If you select this option, you can select on the following in the <i>Target Rate Units</i> screen: <ul style="list-style-type: none"> <li>• Default (kS/a or kS/ha)</li> <li>• Bushels</li> </ul>
	Bushel Weight	Weight per bushel.
<b>Row Monitoring Setup: Alarms</b>		
	High Alarm	Triggers when the seed sensor population rises above the selected percentage from the Target Rate for longer than the delay time.
	Low Alarm	Triggers when the seed sensor population drops below the selected percentage from the Target Rate for longer than the delay time.
	Singulation Low	Triggers when the singulation drops below the selected percentage lower than 100% for longer than the delay time.
	Seeds When Off	Triggers when this percentage of seeds are detected while the sections are off for longer than the delay time.
	No Seeds When On	Triggers when this percentage of seeds are not detected for longer than the delay time.
	Blockage Sensitivity	Triggers when less than this amount of material is sensed for longer than the delay time.
<b>Rate Monitoring Setup: Delays</b>		
	High Alarm	Amount of time that the row sensor population has to be above the High Alarm setting before warning.
	Low Alarm	Amount of time that the row sensor population has to be below the Low Alarm setting before warning.
	Singulation Low	Amount of time that the singulation has to be below the Singulation Alarm setting before warning.
	Seeds When Off	Amount of time that the Seeds When Off setting is above the Seeds When Off Alarm setting before warning.
	No Seeds When On	Amount of time that the Seeds When On is above the No Seeds When On Alarm setting before warning.
	Blockage Alarm	Amount of time that the Blockage Alarm is outside the Alarm setting before warning.

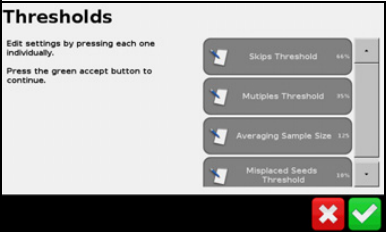
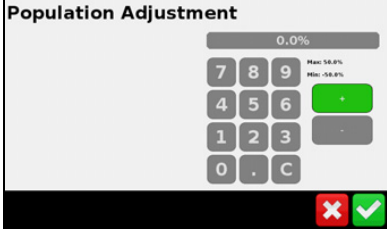
Select ...	Options	Description
<b>Rate Monitoring Setup: Thresholds</b> 	Skips Threshold	If no seeds fall within the percentage of theoretical seed placement, it is considered a Skip.
	Multiples Threshold	If two or more seeds fall within the percentage of the theoretical seed placement, it is considered a Multiple.
	Average Sample Size	The number of seeds used to calculate the averages.
	Misplaced Seeds Threshold	If seeds fall outside of this percentage from the theoretical seed placement, they are considered misplaced and will reduce the spacing quality.
	Population Adjustment	Adjusts the population reading of the seed sensors, independent of the Rate Population.
<b>Rate Monitoring Setup: Population Adjustment</b> 		Set the <i>Population Adjustment Percentage</i> . <b>Note</b> – In most cases this Adjustment setting will be 0%. This feature is for Higher Population Planting.

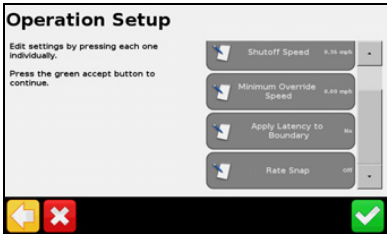
Select ...	Options	Description
<b>Operation Setup</b> 	Jump Start Speed	The speed that the control system will use when the master switch is held in the Jump Start Position. <b>Note – The Rate Switch has to be in Position 1 or 2 for the Jump Start Feature to work.</b>
	Shutoff Speed	The system will shut down if the vehicle drops below this speed.
	Minimum Override Speed	The system will continue to run at this speed if the vehicle drops below this speed.
	Apply Latency to Boundary	<ul style="list-style-type: none"> <li>• Yes: The system starts when needed to begin applying immediately when crossing a boundary.</li> <li>• No: The system starts when the boundary is reached and any mechanical delay could leave a gap between the boundary and where the product is applied. When GPS accuracy is low, this is the preferred selection.</li> </ul> <p><b>Note – This setting only applies to fields that have a boundary.</b></p> <p><b>Note – This setting is also applied when you exit an exclusion zone and return to the workable area of the field.</b></p>
	Rate Snap	<ul style="list-style-type: none"> <li>• Enabled: Shows the Applied Rate the same as the Target Rate when the Applied Rate is within 10% of the Target Rate.</li> <li>• Off: Shows the actual Applied Rate.</li> </ul>

Once you complete all the *Material Type* options, tap  to return to the *Material Setup* screen.

**Note –** Once you tap  in the *Operation Setup* screen, the setup of this material is complete. The *Material Setup* screen now shows **New Material** and **Delete All** buttons and a list of the materials you have set up:

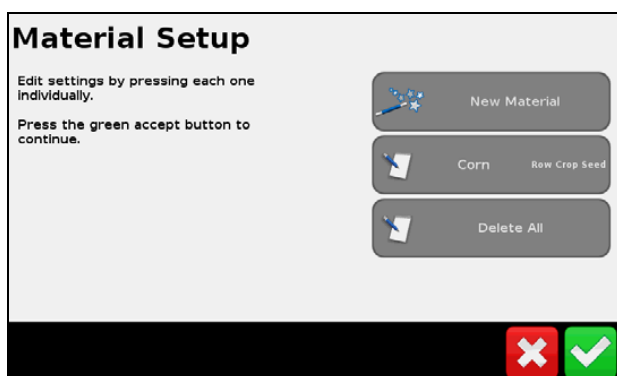



## Setting up a Location

1. In the *Implement* screen, tap **Control Setup**:

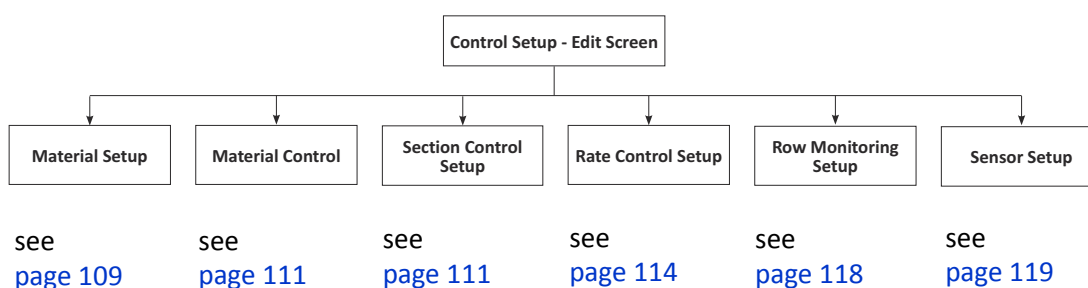

2. In the *Control Setup* screen, tap the location button for the location you want to set up. If this is the first time that you are setting up a control setup, there will be one button only, **Unassigned**.
3. In the *Unassigned* screen, tap **Edit**.



4. In the *Edit* screen, select each option in turn and complete all options and settings. If you tap  you are either taken to the next screen in a sequence, or returned to the *Edit* screen where you can select the next option. Additional options appear as you complete each one.

### Material Setup

The *Material Setup* screen allows you to easily switch the materials into a control location. The location button shows the name of the location and the material that is currently assigned.

Select	Options	Description
Location Name		Select the location name.

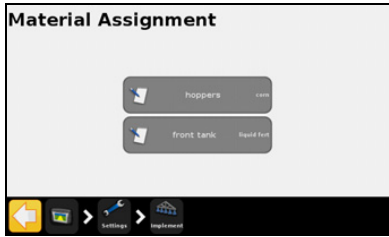
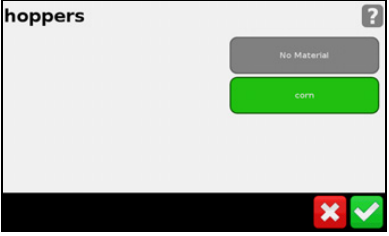
Select	Options	Description
Material Assignment	No Material	This is the default of a location and means that the location is disabled.
	Named materials (for example, Corn, Soy)	<p>Select a material to assign to the location. To change the material, tap the location button (in this example <b>Hoppers</b>) and select a new material. To disable the location, select <i>No Material</i>.</p> <p><b>Note</b> – If the material you require is not listed, exit from this screen and then set it up using the Material Setup procedures. See <a href="#">Setting up a Material, page 103</a>.</p>
		

## Material Control

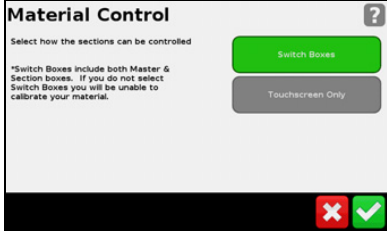
Select	Options	Description
Material Control	Switch Boxes	The location is linked to both the master switch box and the 12-section switch box.
	Touchscreen Only	The location is controlled from the touchscreen.  <b>Note</b> – The FM-750 display requires the use of a 12-section switch box for section control.

## Section Control Setup

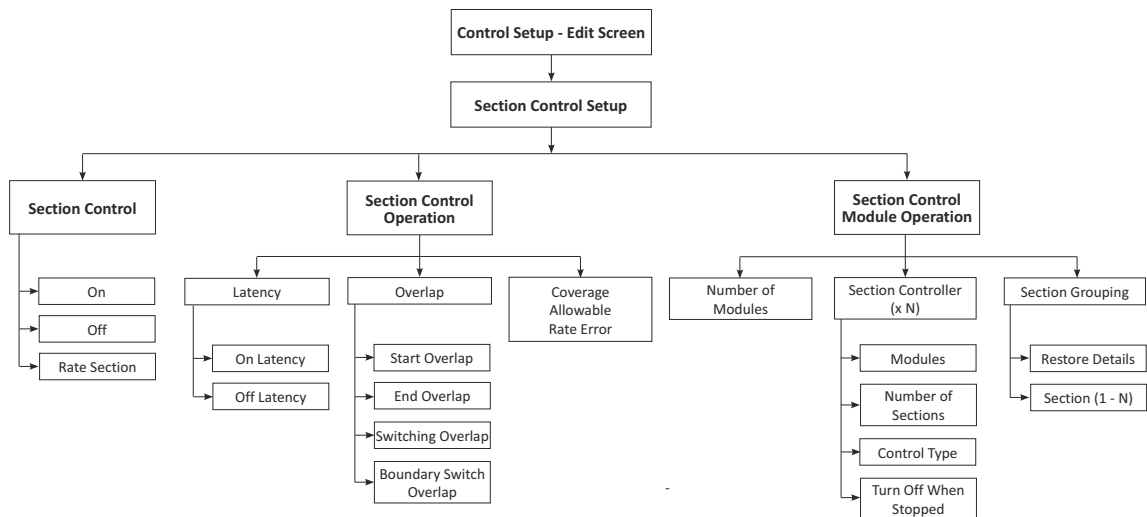

Select	Options	Description
Section Control	On	Turn section control on.
	Off	No section control used for this location.
	Rate As Section	Use the rate control as section control.  <b>Note</b> – This means that the rate will go to zero and shut down the control in a covered area or non-productive zone.

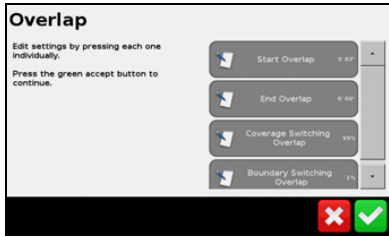
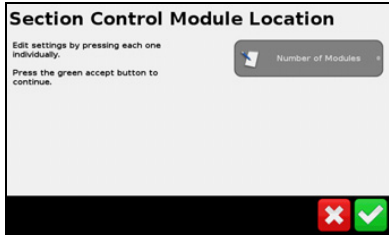
Select	Options	Description
<b>Section Control Operation: Latency</b> 	On Latency <hr/> Off Latency	The length of time that is required before a material is applied when the section is turned on. <hr/> The length of time that is required before a material stops applying once the section is turned off.
<b>Section Control Operation: Overlap</b> 	Start Overlap <hr/> End Overlap <hr/> Coverage Switch Overlap <hr/> Boundary Switch Overlap	The amount of intentional overlap required when leaving already covered area and going into a non-covered section of the field. <hr/> The amount of intentional overlap required when going into a covered area. <hr/> The amount of side-to-side coverage overlap before a section shuts down. <hr/> The amount of side to side boundary overlap before a section shuts down.
<b>Section Control Operation:</b> Coverage Allowable Rate Error		Set the coverage allowable rate error. <b>Note – This setting is used only if you are running very large fields.</b>
<b>Section Control Module Location</b>		This option appears if the <i>Section Control</i> is set to <b>On</b> .
<b>Section Control Module Location:</b> Number of Modules		Select the total number of section control modules for this location.
		

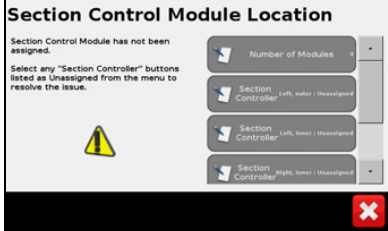
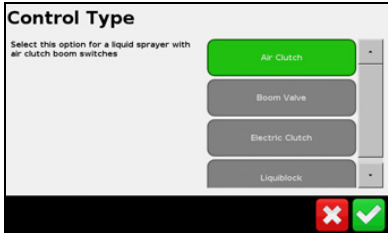
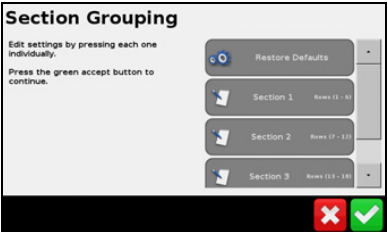

Select	Options	Description
<b>Section Control Module Location:</b> Section Controller 	Modules	<p><b>Select each module in turn and complete its setup before continuing with the next module.</b></p> <p>Select the serial number of the module that you want to assign to the location.</p>
	Number of Sections	<p>Select the number of section to assign to the selected module.</p>
	Control Type	<p>Select the section control type. The options are:</p> <ul style="list-style-type: none"> <li>• Air Clutch: The section control module sends power to the section valve to turn the clutch off.</li> <li>• Boom Valve: The section control module sends power to the section valve to turn the clutch on.</li> <li>• Electric Clutch: The section control module sends power to the section valve to turn the clutch on.</li> <li>• LiquiBlock: The section control module sends power to the section valve to turn the clutch off.</li> </ul>
	Turn Off When Stopped	<p>Select one of the following:</p> <ul style="list-style-type: none"> <li>• Yes: The section closes (turned off) when stopped.</li> <li>• No: The section remains open (turned on) when stopped.</li> </ul>
<b>Section Control Module Location:</b> Section Grouping 	Restore Defaults	<p>Set up the section grouping to match how the sections are physically configured on the implement.</p> <p>Return the settings to the default.</p> <p><b>Note – For the default, the rows are divided evenly across all sections. In most applications this will be the correct setup.</b></p>
	Section 1 - N	<p>Start with Section 1 and select the number of rows that are connected; continue with the sections in order until all rows are assigned.</p>

## Rate Control Setup

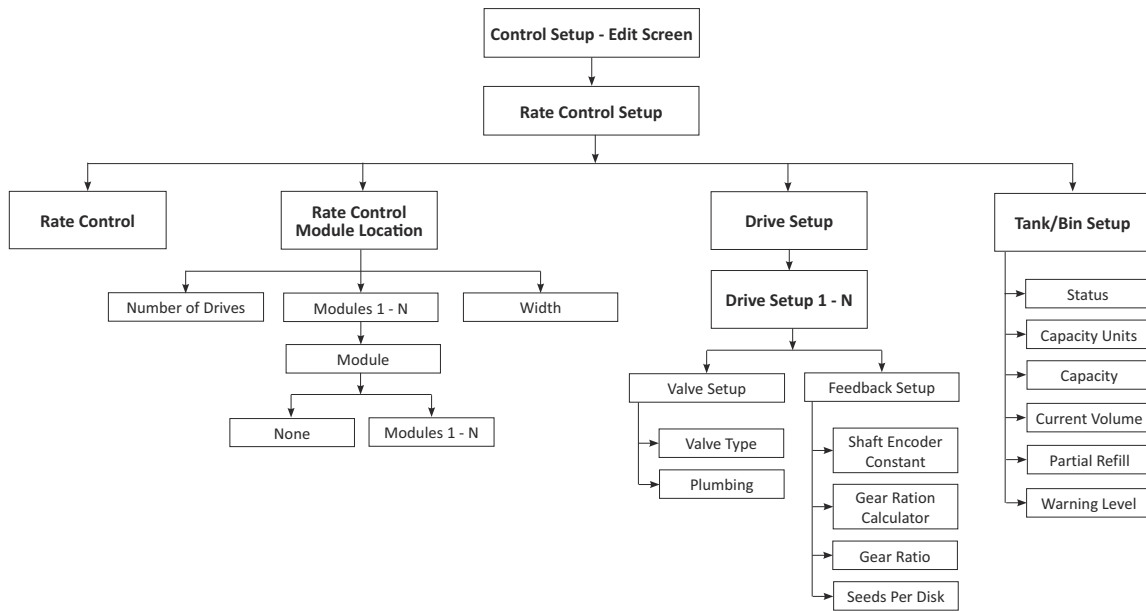



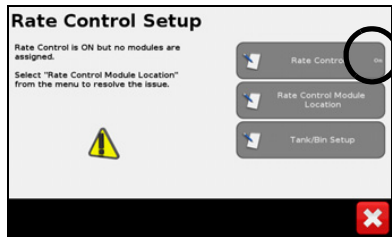

Select	Options	Description
--------	---------	-------------

**Rate Control** Tap the button and then select **On**.

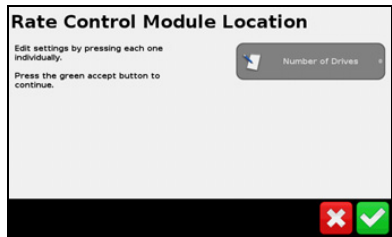

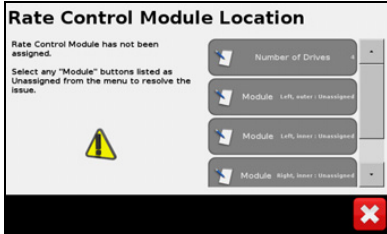
**Rate Control Module Location: Number of Drives** Select the number of drives that you have at the location.

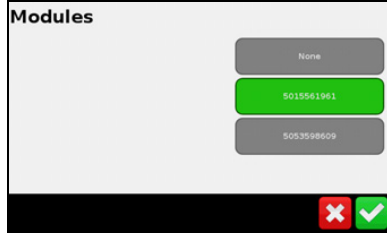

Select	Options	Description
<p><b>Rate Control Module Location:</b> Modules</p> 	<p>Module</p>	<p><b>Select each module in turn and complete its setup before continuing with the next module.</b></p> <ol style="list-style-type: none"> <li>In the <i>Rate Control Module Location</i> screen, select the first module location.</li> <li>In the <i>Module</i> screen, tap <b>Modules</b>:                      </li> <li>In the <i>Modules</i> screen, tap the button showing the serial number of the module physically connected to that location and then tap .                      </li> </ol>
<p><b>Rate Control Module Location:</b> Width</p>	<p>Set the width of the selected location.</p> <p><b>Note</b> – If you have one drive only selected, you will only have one <i>Module Setup</i> to perform and the width is then assumed to be the full implement width</p>	<p><b>Select each drive in turn and complete its setup before continuing with the next drive.</b></p> <p>Select the <b>Drive Setup</b> button showing the serial number of the first drive that you want to set up.</p> <p><b>Note</b> – If you have one module only set up, this screen does not appear—instead the <i>Drive Setup</i> screen with the <b>Valve Setup</b> button appears.</p>
<p><b>Drive Setup</b></p> 		

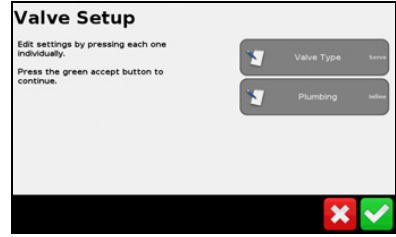
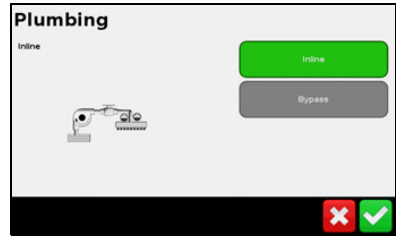
Select	Options	Description
<p><b>Drive Setup: Valve Setup</b></p>  <p><b>Valve Setup</b> Edit settings by pressing each one individually. Press the green accept button to continue.</p> <p>Valve Type</p> <p>Plumbing</p>	<p>Valve Type</p>	<p>Select the <i>Valve Type</i> for the valve physically connected to the module.</p> <p>The options are:</p> <ul style="list-style-type: none"> <li>• Servo: Standard 2-wire servo, performs more slowly.</li> <li>• Servo Fast: Fast 4-wire servo, performs more quickly.</li> <li>• PWM: 2-wire PWM valve, commonly used to control hydraulic flow to the pump.</li> <li>• Hardi % Bypass Servo: Used on Hardi sprayers equipped with 3-way section valves that return flow to the tank when the boom section is off.</li> <li>• Pump Servo: Servo valve commonly used to control hydraulic flow to the pump.</li> <li>• Electric Over Hydraulic: A valve that uses electric current to control the hydraulic valve output.</li> </ul> <p><b>Note</b> – These settings also control the default setting for <i>Valve Response</i>.</p>
 <p><b>Plumbing</b></p> <p>Inline</p> <p>Inline</p> <p>Bypass</p>	<p>Plumbing</p>	<p>Set the valve plumbing for servo-type valves only (that is, Servo, Servo Fast, and Hardi % Bypass Servo).</p> <p><b>Note</b> – Pump Servo does not have a plumbing type as it controls hydraulic flow to the pump. This is similar to a PWM setup.</p> <p>The options are:</p> <ul style="list-style-type: none"> <li>• Inline: The control valve is between the pump and the sections/nozzles. This means that the control valve controls the amount of material out to the section/nozzles directly.</li> <li>• Bypass: The control valve is between the pump and the tank. This means that the control valve controls the amount of material that goes back to the tank.</li> </ul> <p><b>Note</b> – To increase the amount of material that is sent to the section/nozzles, the control valve must open more in order to force more material to the sections/nozzles.</p> <p><b>Note</b> – To increase the amount of material that is sent to the section/nozzles, the control valve must close more in order to force more material to the sections/nozzles.</p>

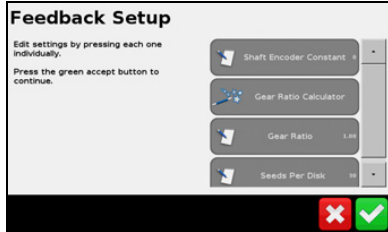
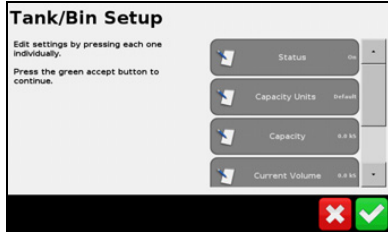
Select	Options	Description
<b>Drive Setup: Feedback Setup</b> 	Shaft Encoder Constant	Enter the pulse per revolution for the feedback sensor you have connected to this module.
	Gear Ratio Calculator	Use the calculator to calculate the gear ratio, if required.
	Gear Ratio	Enter the gear ratio from the feedback sensor to the seed disk.
	Seeds Per Disk	Enter the number of holes in the seed disk.
	Status	Select <b>On</b> to enable the Tank/Bin. Select <b>Off</b> to turn the Tank /Bin setup off.
<b>Tank / Bin Setup</b> 	Capacity Units	Select the units for the Tank/Bin.
	Capacity	Set the total volume for the Tank/Bin.
	Current Volume	Enter the current volume of material in the Tank/Bin.
	Partial Refill	Enter a amount that you want to use for a partial refill.
	Warning Level	Enter the amount of material that you want to trigger a Low Material Warning.

## Row Monitoring Setup

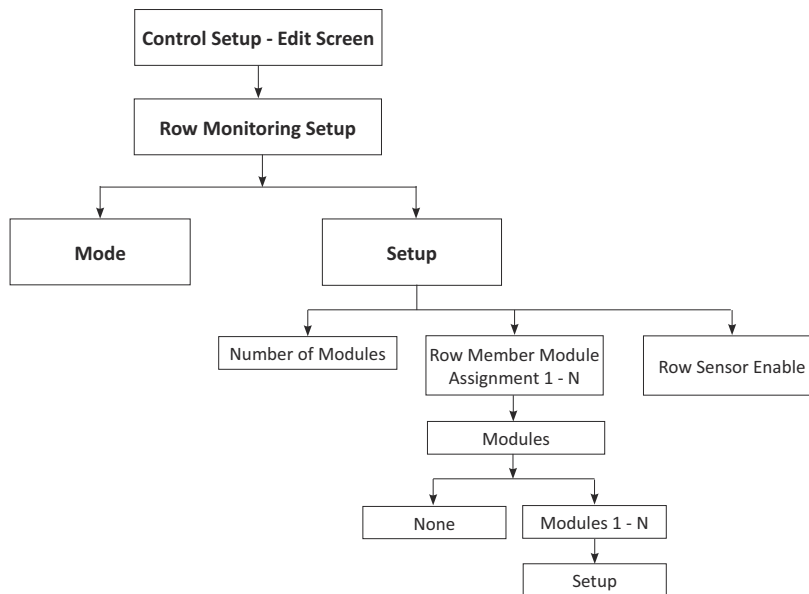

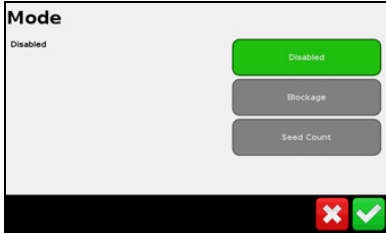
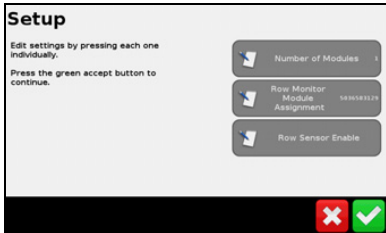
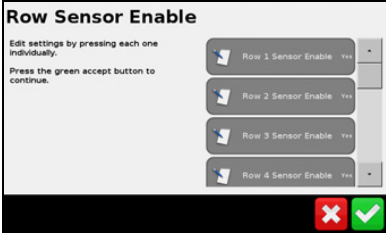
Select	Options	Description
<p><b>Mode</b></p> 		<p>Select the type of row monitoring that you want to enable. The options are:</p> <ul style="list-style-type: none"> <li>• None</li> <li>• Blockage</li> <li>• Seed Count</li> </ul>
<p><b>Setup: Number of Modules</b></p> 	<p>Number of Modules</p>	<p>Select the total number of Row Monitoring Modules you have connected to this location.</p>
	<p>Row Member Module Assignment</p>	<p>Select the button showing the location that you want to set up first and then select the serial number of the row monitoring module connected to this location.</p> <p><b>Note</b> – If you have two row monitoring Modules on this location, repeat these steps, for the second module. You can have no more than two modules per location</p>
<p><b>Row Sensor Enable</b></p> 	<p>Row Sensor Enable</p>	<p>Enable and disable individual sensors.</p>

## Sensor Setup

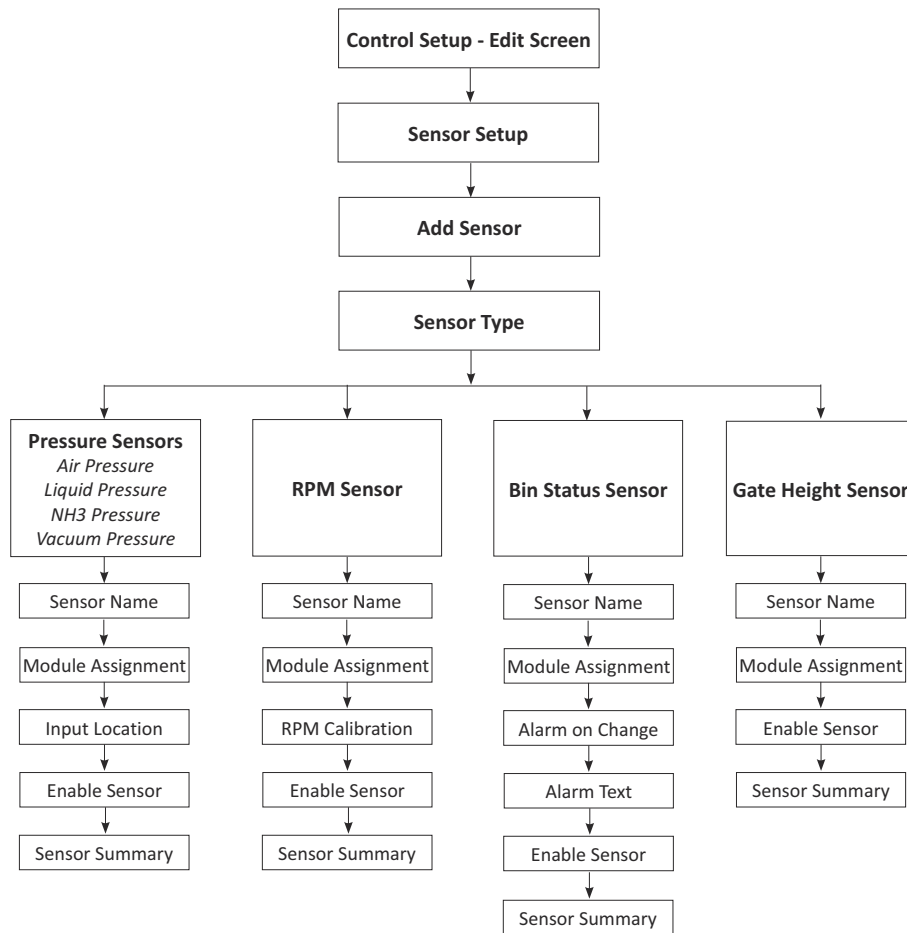

Once you select a sensor type, complete the screens as described below—tap  to move to the next screen. **Not all options apply to all sensors.**

Select	Options	Description
Sensor Type	Air Pressure Liquid Pressure NH3 Pressure Vacuum Pressure RPM Sensor Bin Status Sensor Gate Height Sensor	Select the type of sensor that you want to set up.

**Sensor Type**

Select the type of sensor you want to add



Air Pressure

Liquid Pressure

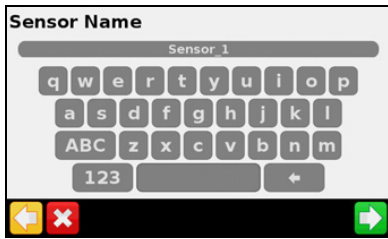
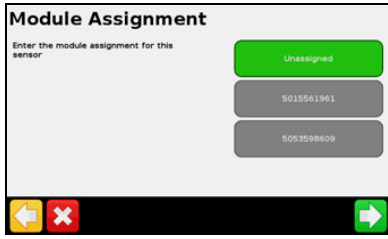
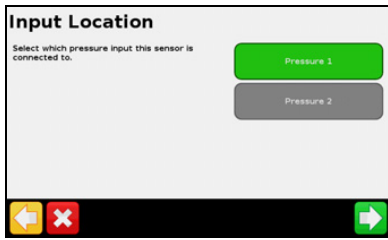
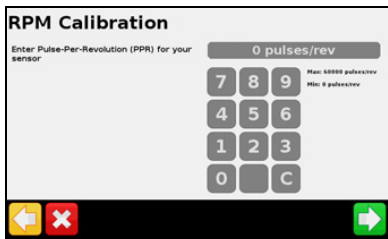

NH3 Pressure

Vacuum Pressure

✕
➔

Select	Options	Description
<p>Sensor Name</p> 		Use the on-screen keyboard to enter a name for the sensor.
<p>Module Assignment</p> 		Select the serial number of the module the sensor is connected to.
<p>Input Location (<i>Pressure Sensors only</i>)</p> 		Select the location the pressure sensor is connected to on the module.
<p>RPM Calibration (<i>RPM Sensors only</i>)</p> 		Enter the Pulse per Revolution number for the RPM sensor.
<p>Alarm on Change (<i>Bin State Sensors only</i>)</p> 	<ul style="list-style-type: none"> <li>Low to High: The alarm is triggered when the module sees the sensor go from 0 V to 12 V.</li> <li>High to Low: -The alarm is triggered when the module sees the sensor go from 12 V to 0 V.</li> </ul>	

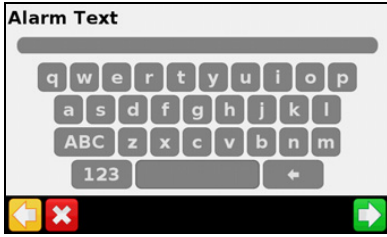
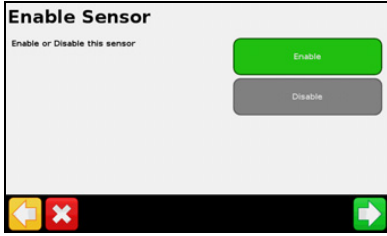

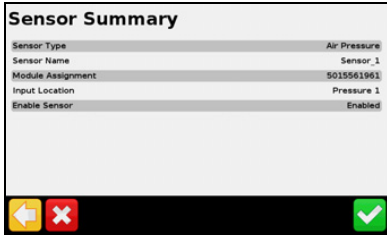
Select	Options	Description
Alarm Text <i>(Bin Status Sensors only)</i>		Enter the text you want to appear when the alarm is triggered.
		
Enable Sensor		Enable or disable the sensor.
		
Sensor Summary		Review the summary. If correct, tap  .
		

## Field-IQ Hydraulics Test

 **WARNING – MOVING PARTS DURING THIS TEST!** Please stay clear of the implement. Ensure the implement is raised, the transmission is in PARK and the emergency brake is applied before continuing.

After the setup wizard is complete, the display tests the hydraulics of your system. During this test you must run the motor(s) at the minimum and maximum RPM and make sure the motor(s) achieve these RPM.

### Field-IQ Calibrations

After the hydraulics test is complete, the display calibrates your system. The available calibrations are:

- Field-IQ Rawson Control Module
- Servo Pump or PWM Pump
- Pressure Sensors

- Implement Lift Switch

When the calibration is complete, save the data to a configuration file and export it to the USB drive. See [Chapter 11, Data](#).

## Field-IQ System Status

Select this option to view the status for the following:

- Master Switch Module
- Section Switch Module
- Rate Control Module
- Section Control Module
- OEM Switch Interface
- Accessories

## Material Assignment screen

The Material Assignment screen allows you to easily switch a material in a control location. The location button (in this example, *Hoppers*) shows the name of the location and the material (in this example, *Corn*) that is currently assigned.

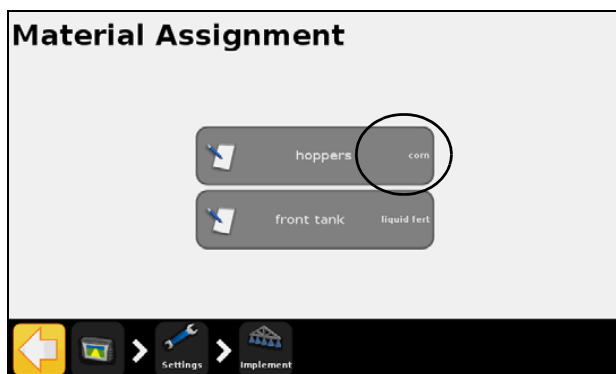

To change the material, tap the location button and then select a new material. If you select *No Material*, the location is disabled.

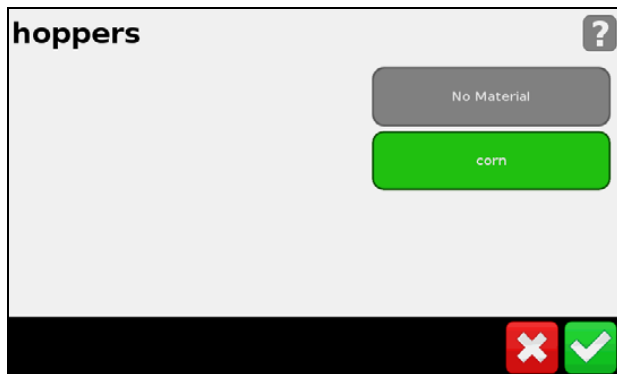







## Operation

Once you have enabled, configured and calibrated your Field-IQ crop input control system, the following items may appear on the guidance screens:



Item	Description	Notes
1	Material	Use this button to switch between materials

Item	Description	Notes
②	Virtual Rate button	Opens the second image (shown to the right) where you can adjust your rates.
③	Virtual Section Auto / Manual switch	Shows the current mode for the controller. The options are Automatic  and Manual 
④	Virtual Master Switch	Shows the Master Switch status. The options are On  and Off 
⑤	Rate switch position	Indicates the current position of the rate switch.
⑥	Quick Access icon	See <a href="#">Quick Access icon</a> , page 34.
⑦	Coverage status	On:  Off:  Inactive: 
⑧	Target rate	The target application rate for the current rate switch position. This is the amount of product that you want to apply.
⑨	Actual rate	The actual application rate. This is the amount of product that is currently being applied.
⑩	Row monitoring bar	
⑪	Sensor Information	Shows current information for the selected sensors.
⑫	Cycle button	Available if you have more than 12 rows to view.

## Field-IQ master switch box



Feature	Function
❶ Increment/decrement switch	Increases the applied amount by a set amount (the amount set in the Setup screen, Rate tab).
❷ Rate switch	Choose to use preset Rate 1, preset Rate 2, or Manual rate.
❸ LED indicator	Red – Unit is powered but not communicating with the FM-750 display. Green – Unit is powered and communicating with the FM-750 display. Yellow – Unit is initializing communications with the FM-750 display.
❹ Automatic/Manual section switch	Automatic mode – The FM-750 display automatically opens and closes sections when entering areas of overlap, non-apply zones, or crossing boundaries. Manual mode – The sections are controlled manually, bypassing the FM-750 display. You can switch from Automatic to Manual mode while traveling.
❺ Master switch	<ul style="list-style-type: none"> <li>• <b>A. Jump start</b> (top position) The sections and rate are ready to be commanded by the FM-750 display, and the system is overridden to use a preset control speed (the speed is set in the Setup screen, Override tab). Use the jump start function if you lose a GPS signal or you want to start applying before your implement is up to speed.</li> <li>• <b>B. On</b> (middle position) The sections and rate are ready to be commanded by the FM-750 display.</li> <li>• <b>C. Off</b> (lower position) Sections are closed and rate is set to zero.</li> </ul>

**Note** – All systems must have a Field-IQ master switch box.

## Field-IQ 12-section switch box



**Note** – The 12 section switch box is required for section control. For rate control only, the switch box is optional.

Only one section switch box can be used on each system. Each section switch is automatically assigned to the corresponding module. The modules are read from left to right. For example, switch 1 assigns to the module furthest on the left when standing behind the implement.

The section switches have different functions, depending upon the status of the master Automatic/Manual section switch on the master switch box.

When the Automatic/Manual section switch is in the **Automatic** position:

- If the section switch is in the on/up position the section(s) assigned to it are commanded automatically by the FM-750 display.
- If the section switch is in the off/down position the section(s) assigned to it are commanded to be off.

When the Automatic/Manual section switch is in the **Manual** position:

- If the section switch is in the on/up position, the section(s) assigned to it are commanded to be on. This overrides the FM-750 display and coverage logging is ignored.
- If the section switch is in the off/down position, the section(s) assigned to it are commanded to be off. This overrides the FM-750 display and coverage logging is ignored.

The LED has the following status indicators:

- Green – The unit is powered and is communicating with the FM-750 display.
- Yellow – The unit is initializing communications with the FM-750 display.
- Red – The unit is powered but not communicating with the FM-750 display.

# Field-IQ Boom Height Control System

## In this chapter:

- [Installing the Boom Height Control hardware](#)
- [Setting up the Boom Height Control system](#)
- [Using the Boom Height Control system](#)

The Field-IQ Boom Height Control system enables the FM-750 display to control the height of spray nozzles above a crop canopy or bare ground.

## Installing the Boom Height Control hardware

For information on installing the Boom Height Control system on your equipment, refer to the *Boom Height Control Platform Installation Instructions*. For the latest versions of these documents, go to [www.trimble.com/agriculture](http://www.trimble.com/agriculture).

## Setting up the Boom Height Control system

1. In the guidance screen, tap .
2. In the **Settings** screen, tap **Implement**:



3. In the *Implement* screen tap **Boom Height Control**:

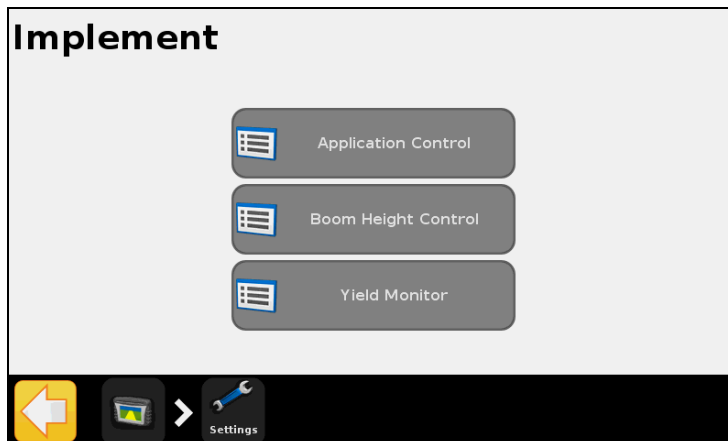





- In the *Height Control* screen, tap **Height Control Setup Wizard**:



- In the next screen, tap **Enable** and then tap :



- In the *Welcome to Boom Height Control Setup* screen, tap  to start the Boom Height Control Setup Wizard.

7. In the *Boom Control Options* screen, select a control option and then tap :

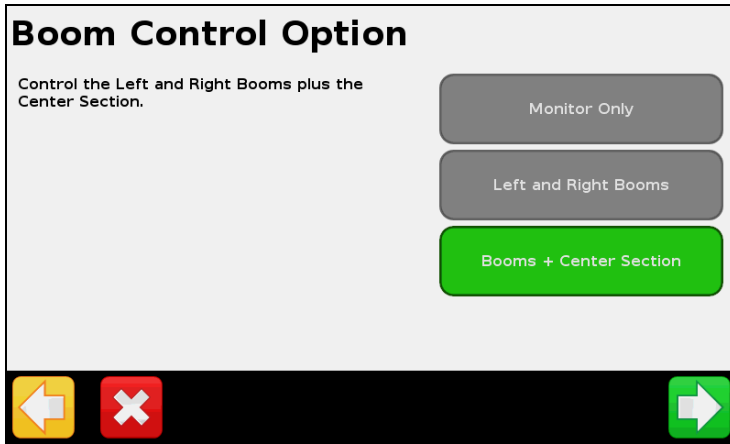

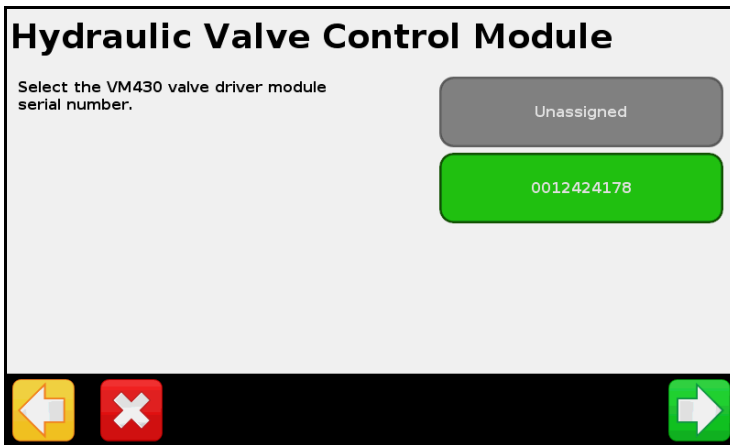

Select...	Description
Monitor Only	Auto-height control is not used. The SS100 sensors are used to monitor the height above the crop or ground.
Left and Right Booms	Auto-height control is used for the wings only.
Booms + Center Section	Auto-height control is used for the wings and the center section.

8. In the *Hydraulic Valve Control Module* screen, select the serial number of the Hydraulic Valve Control module and then tap :

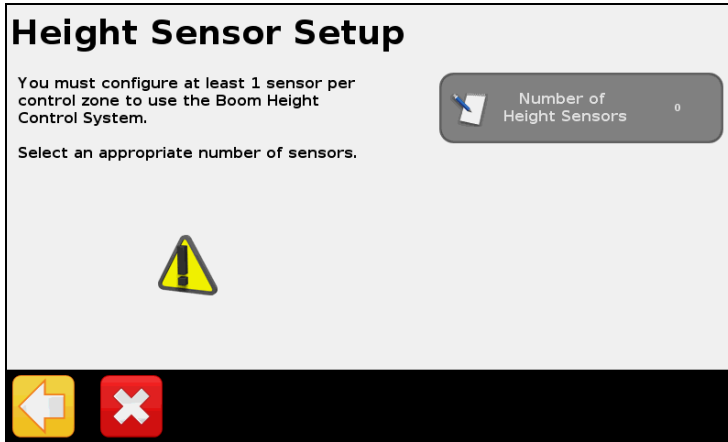

- In the *Height Sensor Setup* screen, tap **Number of Height Sensors**:



- In the *Number of Height Sensors* screen, select the number of height sensors that are attached to the boom and then tap :

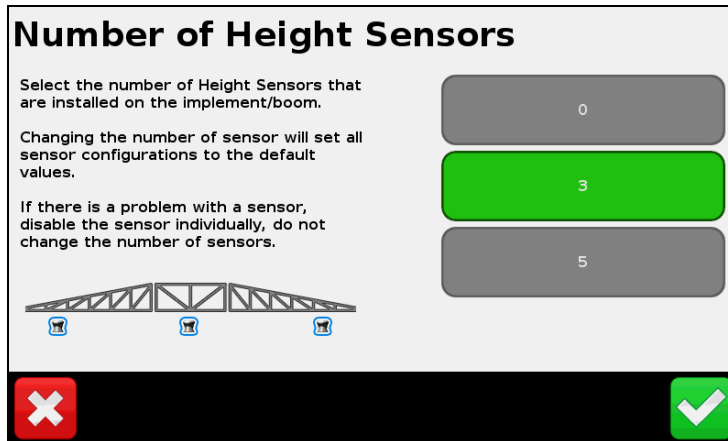

- In the *Height Sensor Setup* screen, tap each of the sensor location buttons in turn:

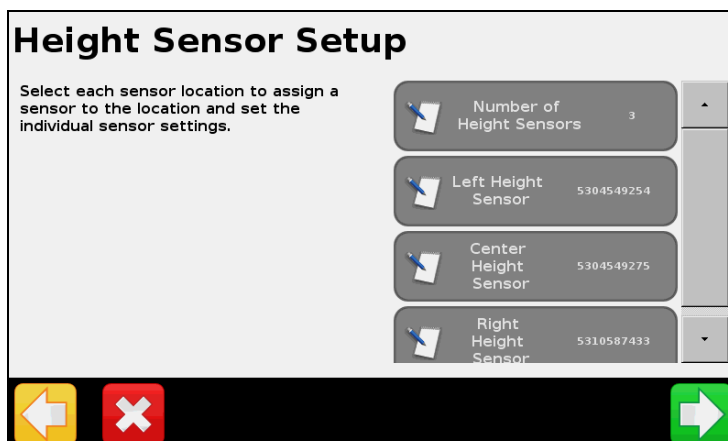

- Set each sensor setting and then tap  to continue.

- Repeat until all sensors are set up then tap 

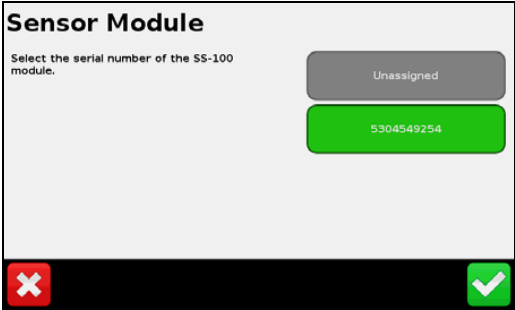
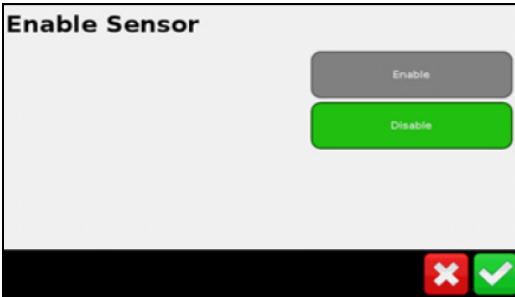
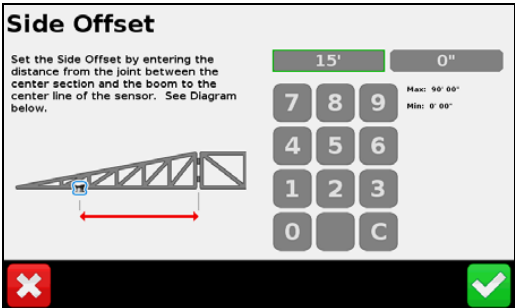
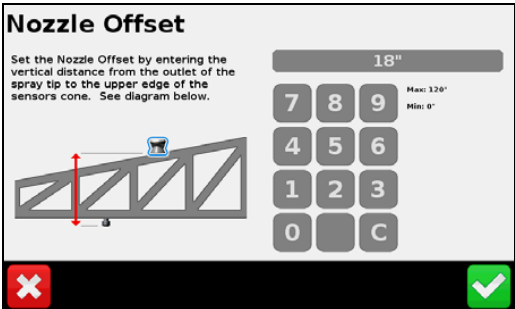
Item	Description
<p>Sensor Module</p> 	<p>Select the serial number of the sensor that is installed in the selected location.</p>
<p>Enable Sensor</p> 	<p>Enable or disable the sensor.</p>
<p>Side Offset</p> 	<p>Enter the distance from the center line of the sensor to the hinge point of the boom.</p>
<p>Nozzle Offset</p> 	<p>Enter the distance from the bottom edge of the sensor cone to the outlet of the spray nozzle tip.</p>

12. In the *Boom Height Manual Control* screen, verify the correct operation of the Manual Boom Switch detection by monitoring the circles next to the control sections. If you use the Raise position on the manual switch, the top circle should turn green. If you use the Lower position on the manual switch, the bottom circle should turn green. Do this for each of the Manual control switches.

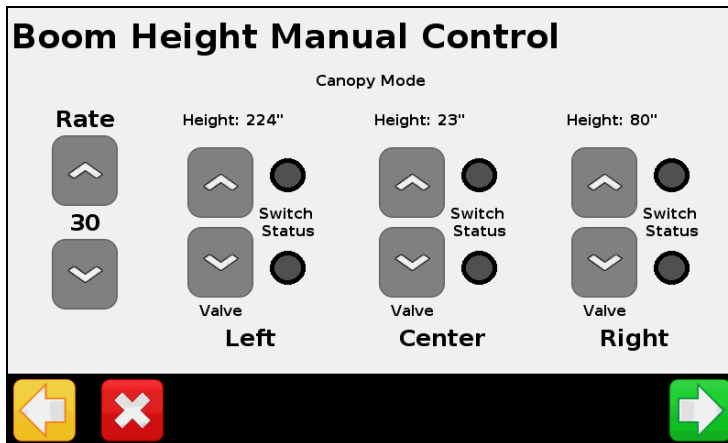

13. In the *Height Control Operation Setup* screen, enter the following:

Item	Description
Sensing Mode	<p><b>Ground:</b> Target height is based on the surface of the ground. Select Ground mode to sense the ground surface through low coverage vegetation, such as stubble or young crops. Ground mode is susceptible to unwanted reflectance on hard or wet surfaces, such as bare ground. If this is an issue, select Canopy mode.</p> <p><b>Canopy:</b> Target height based on the height on the crop canopy. Select Canopy mode to sense the closest object seen. This is used to sense bare ground or high-coverage broad leaf crop canopy.</p>
Target Height	Enter the desired height above the ground or crop canopy, depending on the sensing mode.
Boom Down Rate	Lower this setting to reduce the maximum downward speed of the boom.
Boom Roll Stabilizer	Raise this setting to increase the boom roll stability. <b>Note – Raising this setting will decrease the downward speed of the boom.</b>
Height Error Indication Band	This is the band for which the screen will indicate you are on-target height. <b>Note – This setting is for on screen indication and does not affect performance.</b>
Target Height Step	Enter the distance that the target height should change when you tap Increase or Decrease.
Minimum Target Height	Set the minimum height that the Target Height can be set to. On a multi-sensor control zone, this setting is used as a minimum height for the average of the system. For quicker performance, set this value close to the Target Height setting.
Maximum Target Height	Set the maximum height that the Target Height can be set to.

Item	Description
System Aggressiveness	Set the aggressiveness for the Boom Height Control system. A higher number is more aggressive and a lower number is less aggressive.

## Calibrating the Field-IQ Boom Height system

1. In the guidance screen, tap .
2. In the *Settings* screen, tap **Implement**:



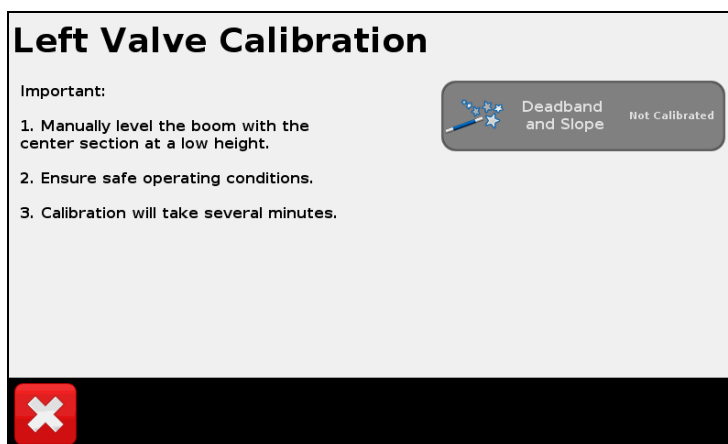

3. In the *Implement* screen tap **Boom Height Control**.
4. In the *Height Control* screen tap **Hydraulic Valve Calibration**.
5. In the *Hydraulic Valve Calibration* screen, tap the **Zone** you want to calibrate.
6. In the Zone Valve Calibration screen, tap the **Deadband and Slope** button:

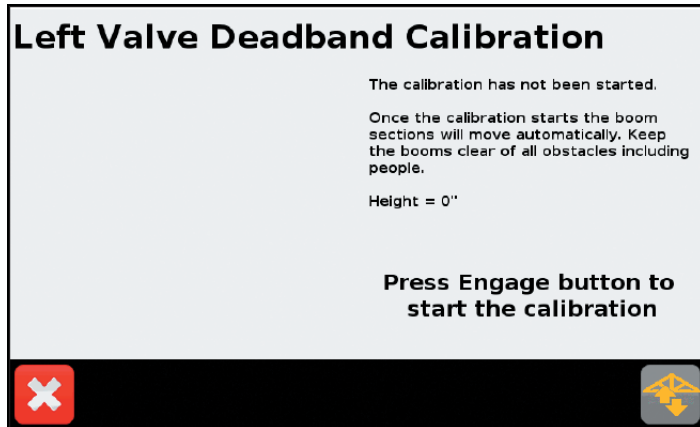

7. Make sure that you lower the center section to a lower height and level the booms before you start the calibration procedure. If the Center or Booms are too high or too low, the calibration may fail.

8. In the *Deadband Calibration* or *Slope Calibration* screen, tap **Engage** to start the calibration.



9. Repeat [Step 5](#) through [Step 8](#) until all zones are calibrated and then tap .

## Using the Boom Height Control system

1. Monitor boom height (before enabling, or if you selected *Monitor Only* on the *Boom Control Options* screen).
2. Enable the zone or zones you want to control.
3. Engage the enabled zone or zones.
4. Use the *Controls* to adjust *Target Height* and *Aggressiveness*.
5. Before transporting the vehicle or folding the booms:
  - Disable boom height control on all zones.
  - Press the **E-Stop** button.
  - Close the field.







## Monitoring boom height

When Boom Height Control is disabled on zones (or of you set *Monitor Only* on the *Boom Control Options* screen) the section buttons are gray.

A symbol on the buttons (for example, a red arrow) indicates:

- The direction that the section is off target
- How far the section is off target

Item	Description
	The boom is significantly below the target height. Raise the boom to reach the target.

Item	Description
	The boom is somewhat below the target height. Raise the boom to reach the target.
	The boom is slightly below the target height. Raise the boom to reach the target.
	The boom is at the target height.
	The boom is slightly above the target height. Lower the boom to reach the target.
	The boom is somewhat above the target height. Lower the boom to reach the target.
	The boom is substantially above the target height. Lower the boom to reach the target.

## Enabling a control zone

When a zone is disabled, the button for that section is gray and Boom Height Control is not available on that section. Enabling a control zone makes automatic height control available for that section.

- To enable a single control zone, tap the button for that section.
- To enable all zones, tap **Enable All**. This button is available only when the system is not engaged and all zones are disabled (gray).

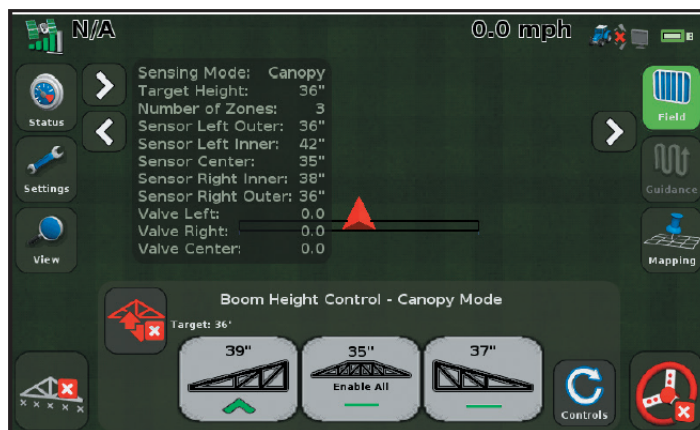

**Note** – If you are currently engaged on other zones, any additional zones will engage automatically.



- Once a zone is enabled, the button for that section turns yellow:

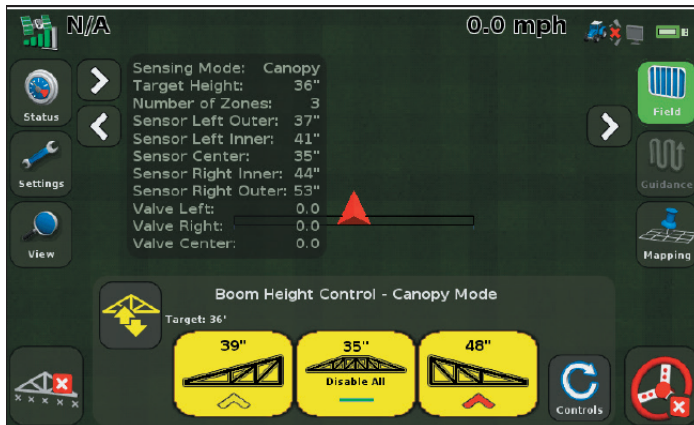

- The **Enable All** button also turns yellow.
  - If all zones are enabled, the center button changes to **Disable All**.
  - If any sections are not enabled, the center button shows the center section.
- The **Engage** button also turns yellow when one or more zones have been enabled:



- Boom Height Control is not active until you engage the enabled zones.

## Engaging enabled zones



To engage all enabled zones, tap **Engage**:

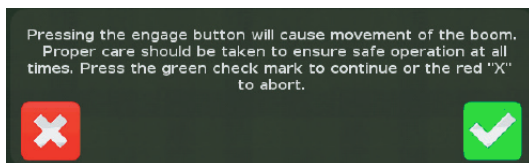

The first time you engage Boom Height Control after the display is turned on, the following safety message appears:



In the safety message screen:

- Tap  to engage the enabled zones.
- Tap  if you do not want to engage the enabled zones.

**Note** – If all zones are enabled but not engaged for 30 seconds, Boom Height Control disables the zones as a safety measure. You must re-enable zones once again before engaging the system.

While Boom Height Control is engaged:

- The **Engage** button is green.
- The button for each engaged section is green.



- The number at the top of each button is:
  - The distance from the sensor to the ground or canopy if the section has one sensor.
  - The average distance from the sensors to the ground or canopy if the section has multiple sensors.
- A symbol on the buttons (for example, a red arrow) shows:
  - The direction that the section is moving to get closer to the target height
  - How far the section is off target (indicated by color)

## Adjusting the Target Height and Aggressiveness Controls

1. Tap **Controls**:



2. The Boom Height Control section of the screen changes to show the *Target Height* and *Aggressiveness* controls:



- To adjust the *Target Height*, tap the increase or decrease arrows below the *Target Height* heading.
- To adjust the *Aggressiveness* of the system, tap the increase or decrease arrows below the *Aggressiveness* heading.
- To set the Target Height to the current boom height, tap **Use Current**.



- To return to the sections view, tap **Boom**:



## Disengaging engaged zones

To disengage a zone, tap the button for that section:

- The button for the section changes from green to yellow.
- Boom Height Control is no longer actively controlling the section, but is still enabled.
- Tapping the button while it is yellow:
  - Re-engages Boom Height Control for that section if any other sections are still engaged.
  - Disables that section if no other section is engaged.

To disengage all zones, tap the green **Engage** button.

- The **Engage** button is green when any zone is engaged.
- When you tap the green **Engage** button, the buttons for all engaged sections change from green to yellow (enabled but not engaged).
- The **Engage** button is yellow when *all* sections are disengaged, and at least one is enabled.

## Disabling Boom Height Control

Before transporting the vehicle or folding the booms:

1. Disengage all zones by doing one of the following:
  - Tap each green section button individually (that is, set each to yellow).
  - Tap the **Engage** button if it is green:



2. Disable all zones by doing one of the following:
  - Tap **Disable All**. This button is available only when all zones are disengaged but enabled.



- Tap the enabled (yellow) sections individually.

**Note** – If any section is still engaged, this will re-engage the section you tap. You must disengage all sections first.

3. Make sure that all zones are disabled:
  - If any button is yellow or green, repeat steps 1-3 until all sections are disabled.

- The buttons for each zone should be gray and the Engage button should be red.



4. Press the **E-Stop** button. The **E-Stop** button is a red hardware button that prevents Boom Height Control from communicating with the equipment. Refer to the *Boom Height Control Installation Instructions* for additional information.
5. To close the field, tap .
6. When asked if you are finished with the current field, tap **Yes**.

Follow the equipment manufacturer's recommendations to fold the booms or transport the vehicle.

**Note** – If the center boom section is raised for 3 seconds using input from a joystick, Boom Height Control is disabled as a safety feature for folding the boom.

# Yield Monitoring System

## In this chapter:

- [Setting up the Yield Monitoring system](#)
- [Calibration](#)
- [In field calibrations](#)
- [In field operations](#)
- [Status items](#)

The FM-750 display supports Yield Monitoring.

This chapter describes how to set up the Yield Monitoring system on the FM-750 display.

# Setting up the Yield Monitoring system

Once you have installed the Yield Monitoring component, you must set up the system.

To do this:

1. From the guidance screen, tap :
2. Tap the **Settings** button:

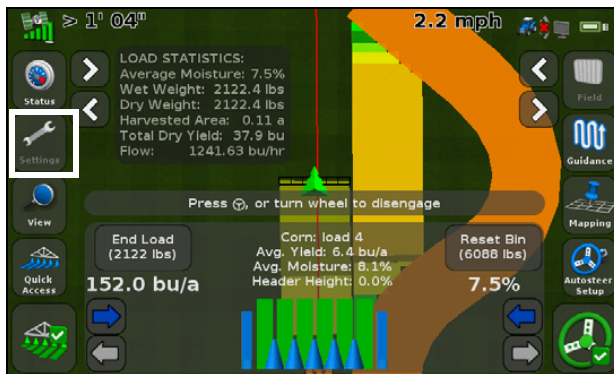

3. Tap **Implement**:



4. Tap **Yield Monitor**:

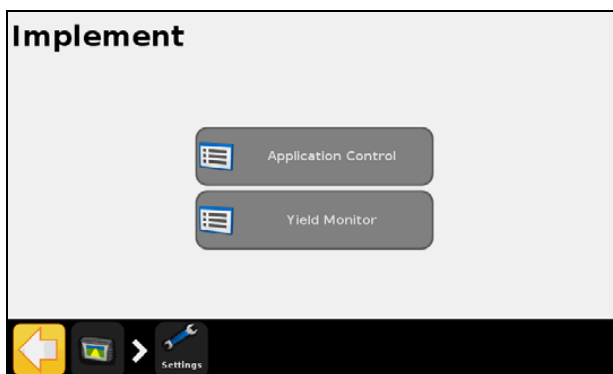

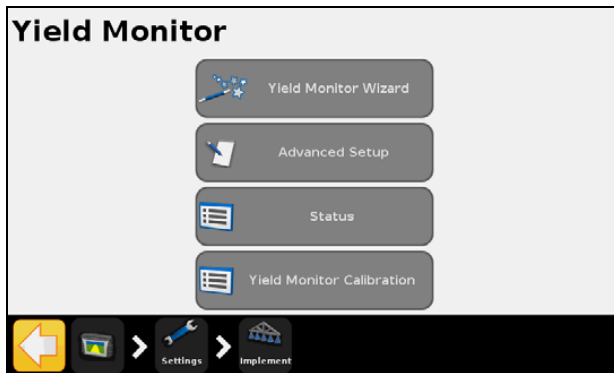
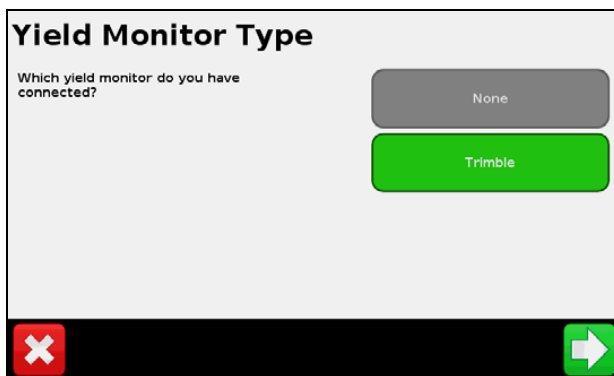
5. Tap **Yield Monitor Wizard**:6. Select the *Yield Monitor Type*:

**Note** – If you select **None**, this removes the Yield Monitor Plugin from the Run screen.

The following screens shows a summary of the hardware attached to the FM-750 display:

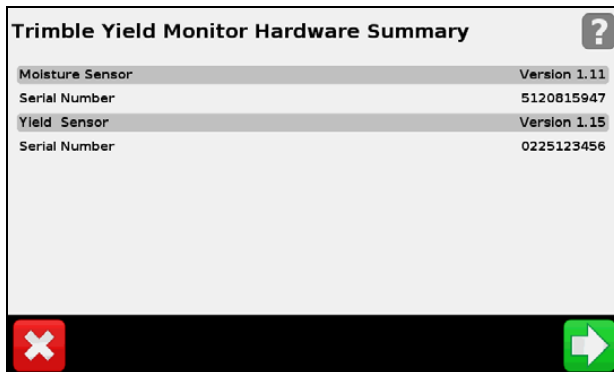

7. In the *Combine Setup* screen, select the **Combine Make**, **Model**, and **Moisture Sensor** type in turn and then tap :

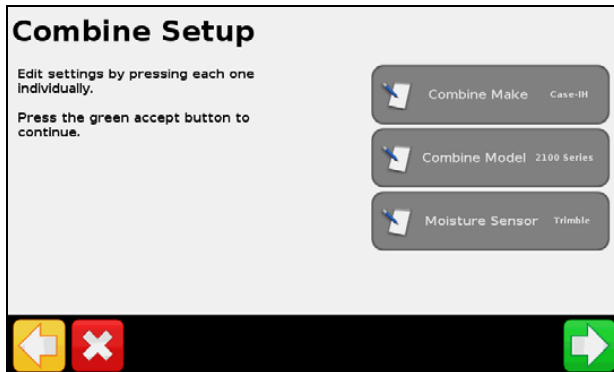

8. In turn, edit each the *Implement Measurement* settings and then tap :

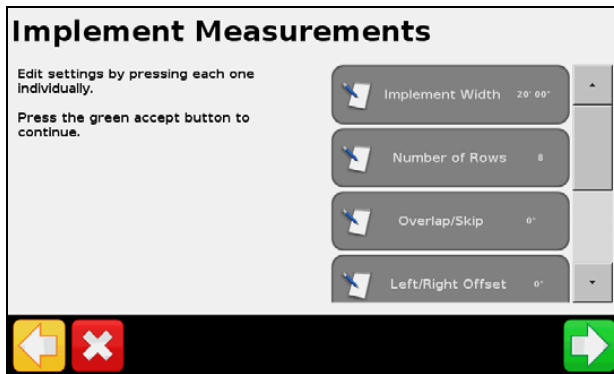

- Implement Width
- Number of Rows (or sections for the header swath control)
- Overlap/Skip
- Left/Right Header offset
- Forward/Back Offset
- Allowable Side to Side coverage overlap



9. Edit the *Yield Monitoring Setup* in accordance with the vehicle requirements and then tap :

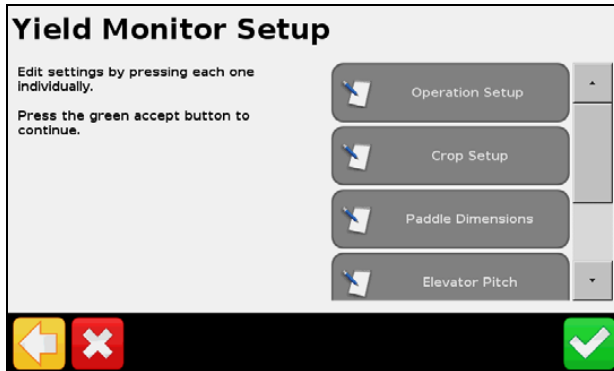

Tap each button in turn and tap  once you have completed the settings required.

**Operation Setup** includes the following:

- a. *Header height Sensor*— **Enable** or **Disable** logging control, based on the header height sensor:

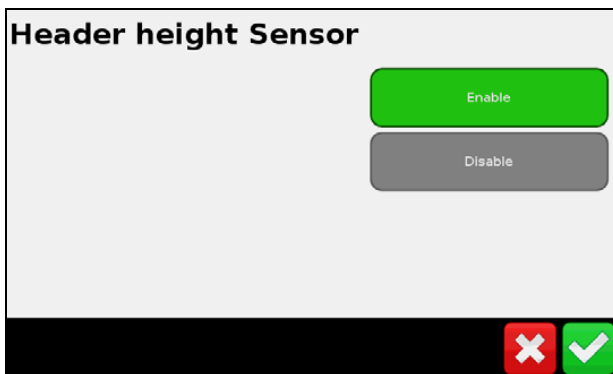

- b. *Header Height*—set the height percentage at which logging turns on and off:

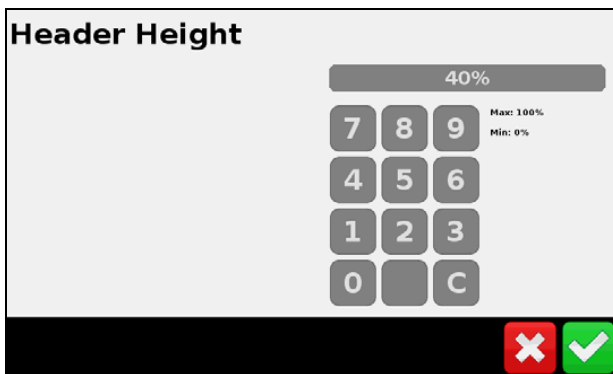

- c. *Grain Flow Delay*—set the length of time the combine takes to process grain for correct mapping of yields. This value should be the time it takes grain to go from the header to the grain tank:

**Grain Flow Delay**

8 s

7 8 9 Max: 100 s  
4 5 6 Min: 1 s  
1 2 3  
0 C

X ✓

- d. *Reset Autocut*—enables resetting of swath control to full width when header is raised and lowered

**Reset Autocut**

Never

When header is lifted

X ✓

**Crop Setup** includes the following:

a. *Commodity*:

**Commodity**

Rice

Sorghum, Grain

Soybean

Wheat

X ✓

b. *Units*—define which units yield will be displayed in:

**Units**

Bushels/a

Tons/a

Lbs/a

Hundred Weight/a

X ✓

c. *Moisture Upper Limit*—the highest moisture value that will be recorded for a crop sample:

**Moisture Upper Limit**

40%

7 8 9 Max: 100%  
4 5 6 Min: 0%  
1 2 3  
0 C

X ✓

- d. *Standard Bushel Weight*—the standard density for the crop being harvested:

**Standard Bushel Weight**

60.00 lbs

Max: 22046.23 lbs  
Min: 0.00 lbs

7 8 9  
4 5 6  
1 2 3  
0 . C

✖ ✔

- e. *Storage Moisture*—the standard moisture that wet yield will be adjusted to for dry yield:

**Storage Moisture**

12.0%

Max: 100.0%  
Min: 0.0%

7 8 9  
4 5 6  
1 2 3  
0 . C

✖ ✔

**Paddle dimensions** enables you to, in turn, verify the length, width, and distance between the paddles on your machine:

**Paddle Dimensions**

Edit settings by pressing each one individually.  
Press the green accept button to continue.

Distance Between Paddles 0' 6.50"

Paddle Width 0' 5.98"

Paddle Length 0' 5.98"

✖ ✔

**Note** – Failure to verify these dimensions can cause degraded performance.

**Elevator pitch** enables you to, in turn, to verify the pitch angle of the clean grain elevator from the vertical and the distance of the sensors from the rear wall:

**Note** – Failure to set the correct optical sensor spacing from the rear wall can cause degraded performance.

**Option Setup** enables/disables the *Start New Load* confirmations. If you enable this setting, the operator has the option to confirm that they want to end the load. If you disable the setting, the operator is not prompted to confirm the end of the load they tap the **New Load** button:

**Bin Volume**—enter the size of the combine's grain tank:

**Bin Display Type**—select to view the current grain bin capacity in either actual units or as a percentage of the bin capacity:

The screenshot shows a menu titled "Bin Display Type" with the instruction "When applying Anhydrous which units do you prefer to work in?". There are two buttons: "Actual Volume" (highlighted in green) and "Percentage" (grey). At the bottom, there are red and green checkmark buttons.

**Map Legend Setup** enables you to determine, in turn, the scale on the Yield and Moisture layers that are displayed on the FM-750 display:

The screenshot shows a menu titled "Map Legend Setup" with the instruction "Edit settings by pressing each one individually. Press the green accept button to continue." There are four buttons: "Low Yield 5.0 bu/a", "High Yield 100.0 bu/a", "Low Moisture 5%", and "High Moisture 20%". At the bottom, there are red and green checkmark buttons.

# Calibration

## Set up calibrations

This section describes the calibrations that you must carry out before going to the field:

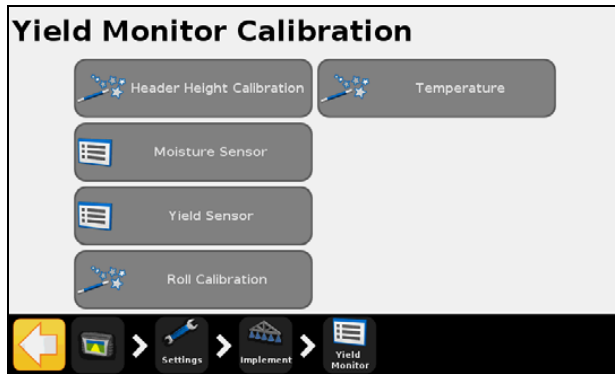



## Header Height Calibration

The Header Height Calibration wizard allows you to set the high and low points for the header height position:

**Note** – For accurate operation, the highest and lowest point of header operation must fall within the 0-5 Volt range of the sensor. If the sensor reaches maximum value **before** the full range of the header movement, you will need to adjust the linkage on the sensor.

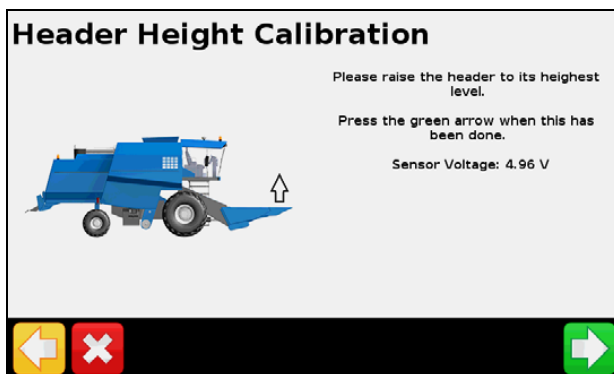
1. Start the wizard, raise the header to its highest point and then tap :



2. Lower the header to its lowest position and then tap :

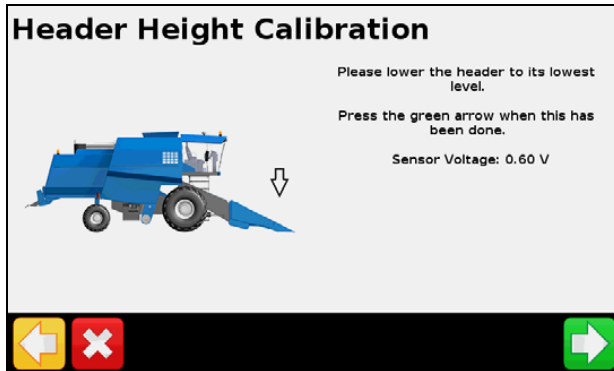

3. Set the *Header Height* percentage at which logging should toggle on and off and then tap :

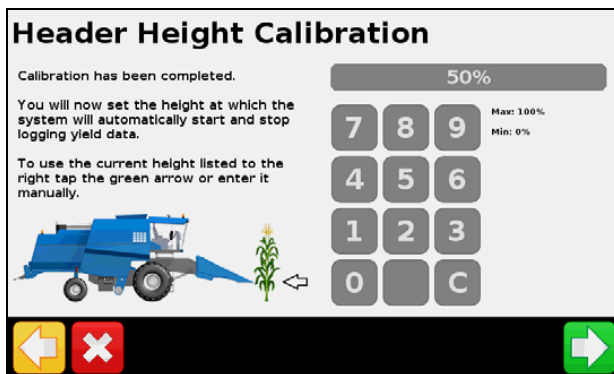

4. Once calibration is complete, tap :

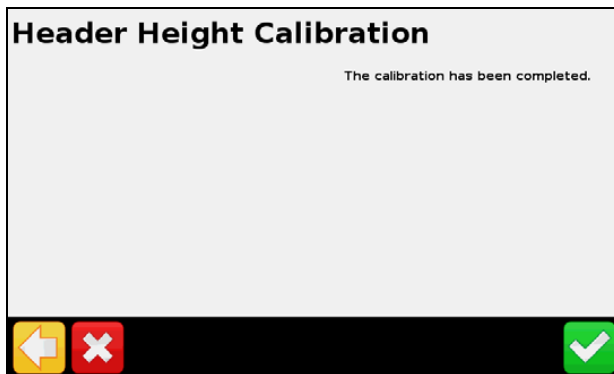

## Moisture Sensor Calibration

This will be performed in the field.



## Tare Calibration

To tare the yield sensor, engage the separator, run the combine at full throttle and then tap :

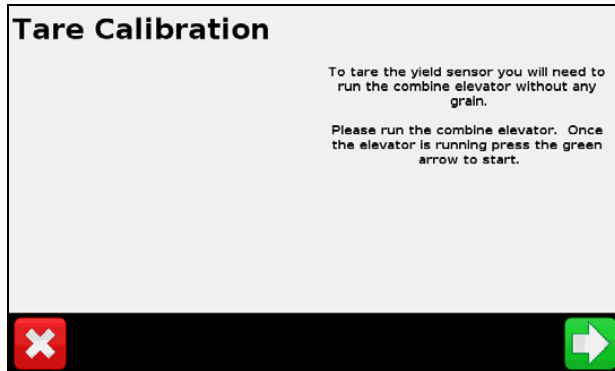

**Note** – Tare Calibration is important to the performance of the system. Ensure that the clean grain elevator is at proper tension with all paddles present and of uniform size.

Tare results should be close to paddle thickness but may be off a little bit. More important is a small deviation of Tare. This value should be less than 25% of the tare:

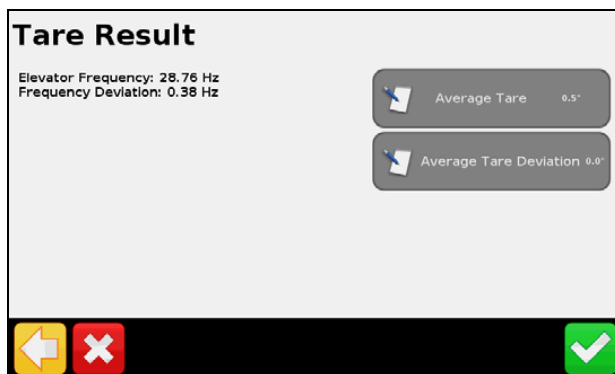

## Temperature Calibration

Park the combine so that the Yield Monitoring Module and moisture sensor are in the shade and place a thermometer next to them for a while. Read the thermometer and then enter the correct temperature:

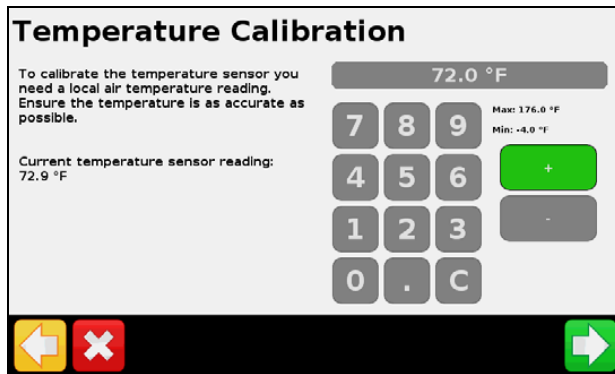



**Note** – Failure to complete this calibration can degrade moisture sensor performance.

## Roll Calibration

The Yield Monitoring Module has inertial measuring devices to compensate for the terrain you encounter while harvesting. You need a GNSS location to perform this calibration.

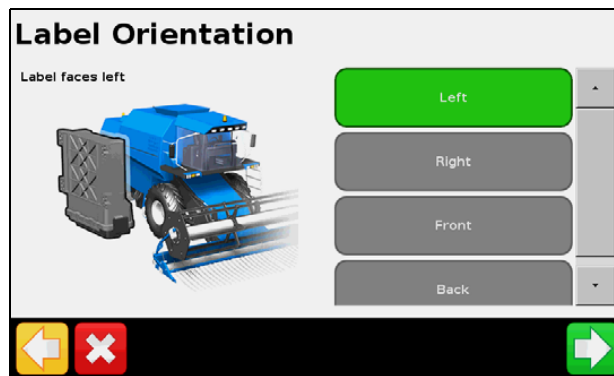
1. Select the *Connector Orientation* and *Label Orientation* relative to the vehicle:



2. Park the vehicle on flat ground, mark the inside position of the front and rear wheels and then tap :



3. Wait while the roll is determined.

4. When prompted, turn the vehicle around so that the front wheels are in the position where the rear wheels were and the rear wheels line up with the marks from the front wheels, tap  and then wait for the roll offset to be determined

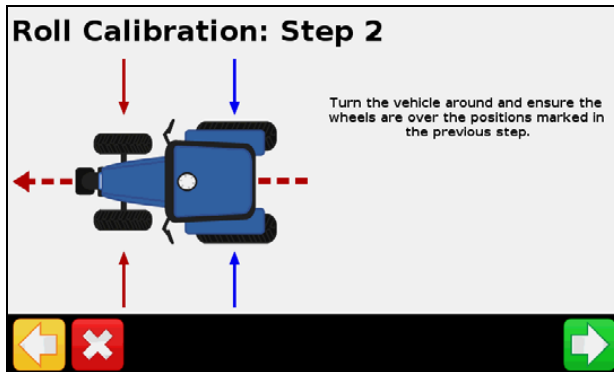

## In field calibrations

For accurate performance of the Yield Monitor, the optical yield sensors and moisture sensor must be calibrated in the field in reference to a known good scale and moisture sensor.

### Yield flow calibration

Calibrating the Yield Monitoring system across the full range of flows improves the accuracy of the system. To obtain a good calibration, do the following:

- Select calibration loads where the conditions are consistent—where the crop quality is as even as possible, the ground is as level as possible, and the passes are as long as possible. Keep the combine speed constant during the entire run.
- Collect loads that are as large as is practical without sacrificing consistency.
- Collect as many different calibration loads as possible, with each load at a different flow rate. To accomplish this, you can run the system at different speeds, or harvest partial header widths.

1. Select one of the following Calibration methods:

- **Speed method.** Uses a consistent header width while varying speed to calibrate for Low, Medium, and High grain flows.
  - a. Conduct a calibration load of 3,000-6,000 lbs. at your normal harvest speed, making sure to keep it constant.
  - b. Repeat this procedure for one load at 1 mph less than the normal operating speed; one load at 2 mph less than then normal operating speed; and one load at 1 mph higher than then normal operating speed.

This provides a calibration curve for Low, Medium, and High flow variations throughout the course of Harvest.

An example of calibration loads using this method is as follows:

Load 1 = 4,547 lbs. @ 2 mph

Load 2 = 3,834 lbs. @ 3 mph

Load 3 = 2,764 lbs. @ 4 mph

Load 4 = 5,768 lbs. @ 5 mph

- **Cut Width method.** This uses a consistent speed with different cut widths to calibrate for Low, Medium, and High flows.
  - a. Conduct a calibration load of 3,000-6,000 lbs. at your normal constant speed with a 100% cut width (that is, 12 rows at 30 ft).
  - b. Repeat this procedure for one load at 75% of the normal cut width (9 rows at 22.5 ft); one load at 50% of normal cut width (6 rows at 15 ft); and one load at 25% of normal cut width (3 rows at 7.5 ft) at the same constant speed.

This provides a calibration curve for Low, Medium, and High flow variations throughout the course of Harvest.

An example of calibration loads using this method is as follows:

Load 1 = 5,768 lbs. @ 4 mph @ 100% swath width

Load 2 = 4,547 lbs. @ 4 mph @ 75% swath width

Load 3 = 3,834 lbs. @ 4 mph @ 50% swath width

Load 4 = 2,764 lbs. @ 4 mph @ 25% swath width

It is highly recommended that you conduct a minimum of three calibration loads to ensure that the system provides accurate readings for all low, medium, and high flows throughout harvest. If you conduct a Single Load calibration, this may result in poor accuracy performance when Harvesting outside the Flow range at which the system was initially calibrated.

2. Collect all calibration loads.
3. Tap the **Quick Access** button and then tap **Load Details**:

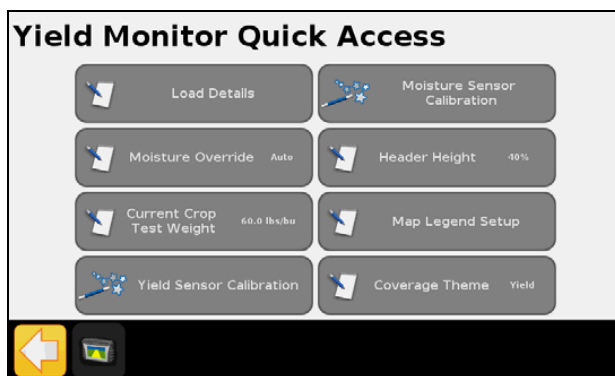

4. For each load:

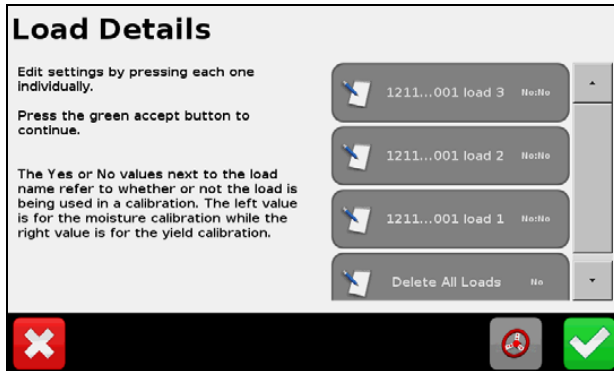

– Tap the load button:

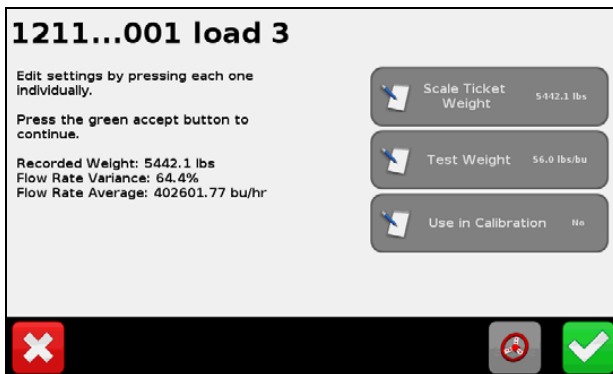

– Enter the Actual Scale Weight and then tap :

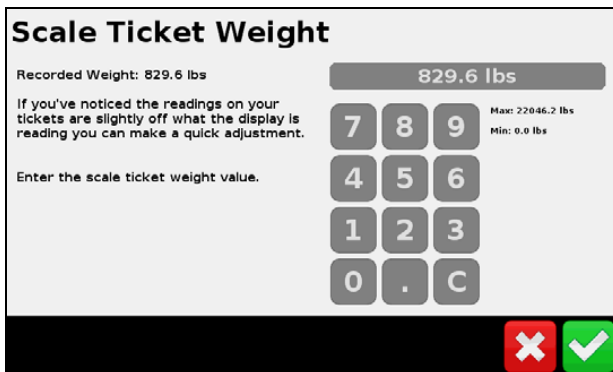

- Enter the Actual Test Weight and then tap :



- Enter the actual moisture for the load.

**Note** – Evaluate each load for the flow variance. Only use loads that have a low flow variation in the calibration.

5. Tap **Yield Sensor Calibration**, tap **Yield Sensor Calibration** again and then tap .

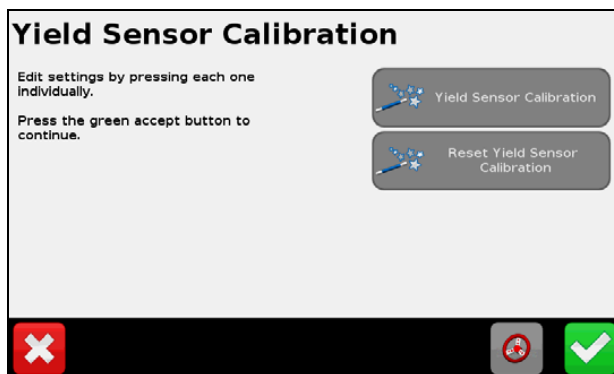

6. Confirm which loads are to be used in the calibration and then tap .

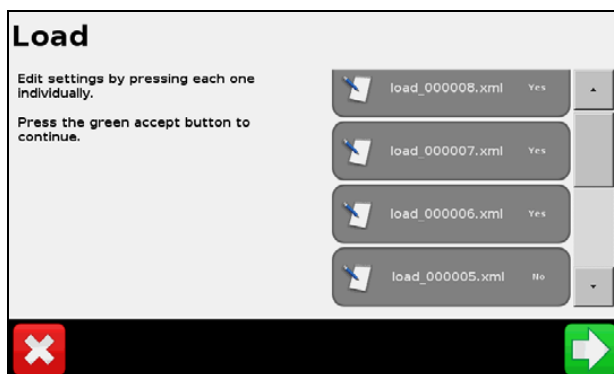

7. Confirm the load adjustments—tap **Yes** or **No** and then tap :



**Yield Sensor Calibration**

Your Calibration will be adjusted by following

load\_000008: 384.8 lbs -65.2 lbs  
 load\_000007: 1148.2 lbs -151.8 lbs  
 load\_000006: 643.4 lbs -106.6 lbs

Yes

No



8. Confirm whether you want to apply the sensor calibration to previously recorded loads in the field—tap **Yes** or **No** and then tap :

**Yield Sensor Calibration**

Would you like to apply this calibration to all the previously recorded loads?

Yes

No

A message appears stating that the current field has been calibrated successfully.

9. In the *Yield Monitor Quick Access* screen, tap **Moisture Sensor Calibration**:

**Yield Monitor Quick Access**

Load Details

Moisture Sensor Calibration

Moisture Override Auto



Header Height 40%

Current Crop Test Weight 60.0 lbs/bu

Map Legend Setup

Yield Sensor Calibration

Coverage Theme Yield

 



- Tap **Scale Ticket Moisture** and enter the correct moisture from the scale ticket; tap **Use in Calibration** if you want to use the value in the calibration and then tap :

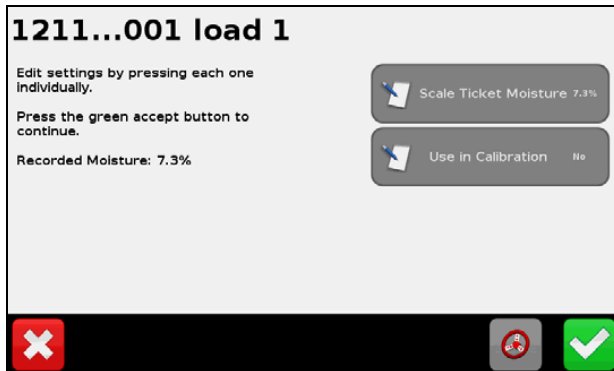

- Tap **Yes** and then tap  to confirm the Calibration adjustments:

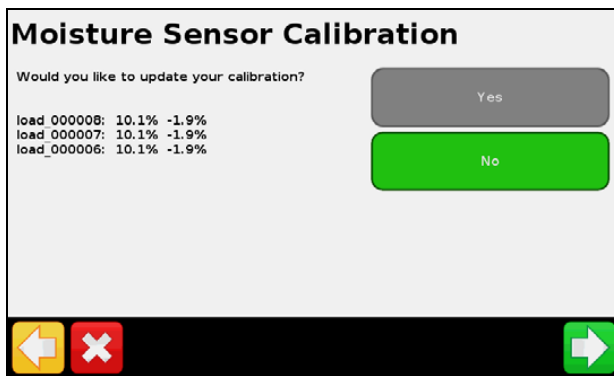

## In field operations

- Tap **Status** to scroll through *Field* or *Load Statistics* or the map legend:



- Tap the arrow buttons to increase or decrease header swath width: Tap **Status** to scroll through *Field* or *Load Statistics*:



- Tap **New Load** to start and stop loads for calibrations and load tracking. The FM-750 display can hold up to 250 loads:

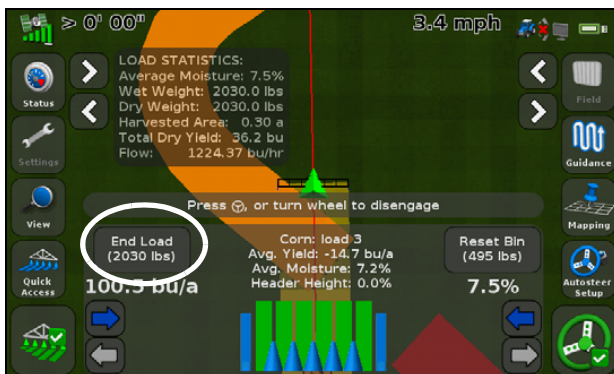

- Tap the logging button to manually turn logging on or off.

**Note** – The header height function will turn it on and off in accordance with the header position:

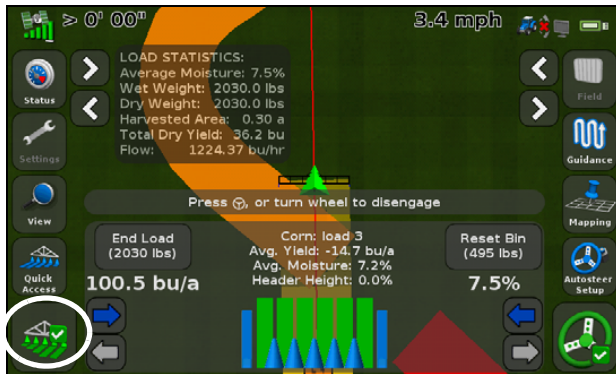

The Legend correlates the yield to the color shown for the current coverage theme:



- You can use the grain *Bin* level status item to track the amount of grain in the Grain Bin. Set up the size of the grain bin in the Yield Monitoring Setup wizard. Tap the button to reset the counter:

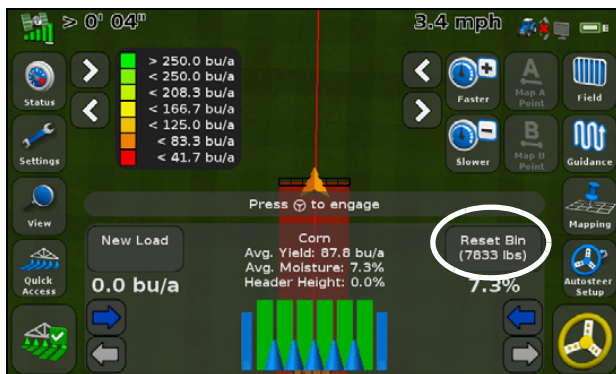

- Tap *Quick Access* to access the Yield Monitor Quick Access menu and then tap **Coverage Theme** to change the coverage layer theme:

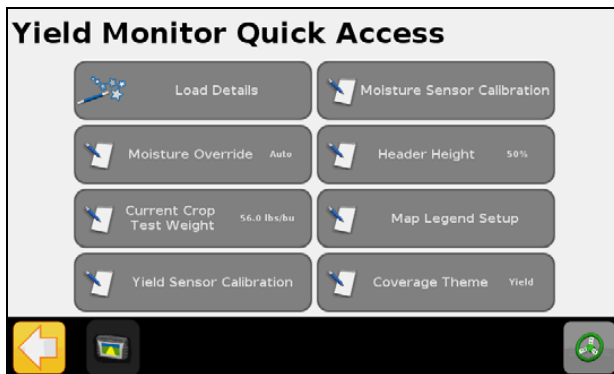

You options in the Coverage Theme screen are *Yield*, *Moisture*, and *Overlap*:



In the *Moisture Override* screen, tap **Manual** to turn off the automated moisture sensor readings and apply a constant moisture value to the crop being harvested. You can enter the test weight of the crop being harvested to maintain yield monitoring accuracy:

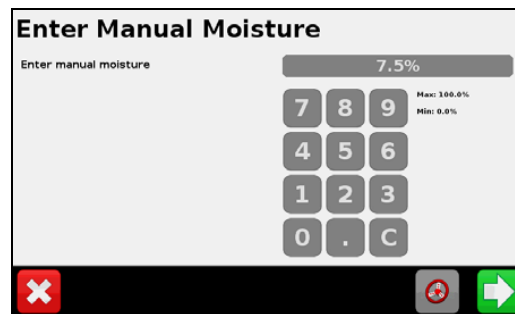



You can enter the test weight of the crop being harvested to maintain yield monitoring accuracy:

**Current Crop Test Weight**

Enter test weight 56.0 lbs/bu

Max: 776.6 lbs/bu  
Min: 0.0 lbs/bu

7	8	9
4	5	6
1	2	3
0	.	C

 

## Status items

- The *Yield Monitor Status* screen provides detailed information on the system:

**Yield Monitor Status**

Field Wet Weight	0.00 lbs	▲
Load Wet Weight	0.00 lbs	
Moisture	7.37%	
Header Height	100.00% (0.00 V)	
Roll Angle	90.00°	
Pitch Angle	90.00°	
Flow	0.00 bu/hr	
Temperature	70.3 °F	
Density	56.00 lbs/bu	
Tare	0.42"	▼



- The *Sensor Status* screen provides information on the optical sensor operation:

**Sensor Status**

Optical Sensor	Active
Noise Level	0.00%
Elevator Speed	0.000 Hz
Percent Dark	0.00%
Moisture Sensor	Active
Sensor Value	6.86% (1.581 V)
Temperature	67.9 °F



# Mapping and Guidance

## In this chapter:

- [Introduction](#)
- [Configuring the Guidance settings](#)
- [Starting Guidance](#)
- [Fields](#)
- [Resetting guidance](#)
- [Guidance lines](#)
- [Guidance patterns](#)
- [Line Feature Guidance](#)
- [Coverage logging](#)
- [The pause / resume function](#)
- [Curve smoothing](#)

This chapter describes the type of guidance information that the FM-750 display provides.

## Introduction

While you work, guidance information appears on the FM-750 display screen and the integrated lightbar that indicate the:

- position of your vehicle in the field
- guidance lines
- offline distance

To receive this guidance information (and any assistance from an auto steer system) you must do the following:

1. Configure how the guidance appears on your screen. See [Configuring the Guidance settings](#), below.
2. Set a guidance line. See [Guidance lines](#), page 175.
3. Configure the lightbar. See [Lightbar Setup](#), page 210.

## Configuring the Guidance settings

1. From the guidance screen, tap .
2. From the *Settings* screen, tap **Guidance**.

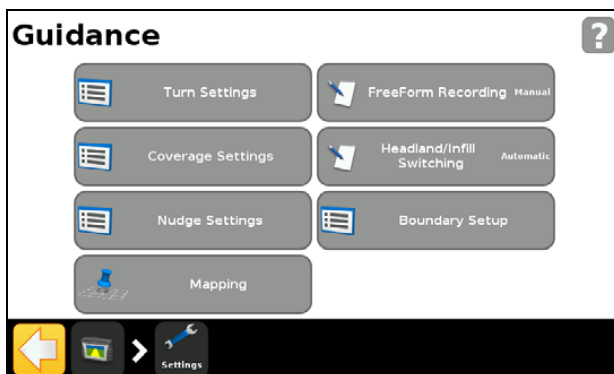

3. Select the options to configure.

Option	To learn more, see ...
Turn Settings	<a href="#">page 168</a>
Coverage Settings	<a href="#">page 168</a>
Nudge Settings	<a href="#">page 169</a>
Mapping	<a href="#">page 169</a>
FreeForm Recording	<a href="#">page 170</a>
Headland/Infill Switching	<a href="#">page 170</a>
Boundary Setup	<a href="#">page 170</a>

## Turn Settings

The available Turn Settings are described below.

### Minimum turn radius mode

This setting smoothes corners on curved AB lines, which optimizes the accuracy of your auto steer system when steering curves.

Use this mode ...	To ...
Automatic (This is the default mode.)	Set the radius to 80% of the swath width or 32.8' (10 m), whichever is larger.
Disabled	No attempt is made to keep the corners above a minimum turn radius. <b>Note</b> – <i>If you use this mode, curves may be very tight and the auto steering system may be unable to successfully complete the turn.</i>
Manual	Manually choose the minimum radius.

### Tight turn alert threshold

The FM-750 display alerts you when your machine is within a specified distance of a tight turn.

The threshold is set between 1 and 10. To increase the sensitivity of the alert, lower the number.

### Auto U-turn detection

Auto U-turn detection operates only on FreeForm™ and adaptive curve patterns. For more information, see [Guidance patterns, page 176](#).

Use this mode ...	To ...
On	Automatically detect that the vehicle has done a U-turn and generate the next guidance line.
Off	Manually control when a path is finished. With the FreeForm pattern, you must manually stop recording. With the adaptive curve pattern, you must manually set the B point.

## Coverage Settings

Configure the *Coverage Settings* options to suit the requirements of your system.

### Coverage on/off delay

If you activate coverage logging at the same time as you enable your spraying or spreading system, set a coverage delay that matches the time it takes for flow to start when you turn on your spraying/spreading system. This ensures that the display records coverage from the actual start point of application. You can enter a delay time between 0.0 - 10.0 seconds.



## Coverage logging

**Note** – Coverage logging can be recorded at speeds as low as 1.3 km/h (0.8 mph).

Use this mode ...	To ...
Disabled	Turn coverage logging off.
Manual	Turn coverage logging on and off manually.
Engaged	Automatically enable coverage logging when the auto steer system is engaged.
Switch	Use a remote switch to turn coverage logging on or off.

## Nudge Settings

Option	Description
Clear nudge at swath end	When enabled, the display clears the nudged position each time you change swaths.
Reset nudge	When enabled, any applied nudge is cleared and all swaths return to their original positions.
Nudge increment	Each nudge moves the guidance line by this value. The default nudge increment is 0' 1" (2.5 cm). Enter a value between 2 - 12" (3 - 30 cm).

## Mapping

Use this setting to set warning distance and recording positions for the following features:

- Point
- Line
- Area

### Warning distance

You can set a warning distance so that the FM-750 display alerts you when your machine approaches a feature.

As the machine moves to within the specified distance, a warning screen appears on the display. If you have an EZ-Steer or Autopilot system with a sonalert connected, an audible alarm also sounds.

You can set the warning distance to between 0'00" - 984' 03" (0.0 - 300.0 m).

### Recording position



Choose the point at which a feature is recorded. When your vehicle is at this point, the feature will be recorded.

## Delete features

Use this function to delete point, line, and area features from a selected field. Only the features are deleted—not the field itself.

## FreeForm Recording

Use this setting to choose how the display records a FreeForm pattern:

Select this mode ...	To ...
Manual	Use the icons on the guidance screen to control when the path is recorded. To start recording tap  , to stop, tap  .
Record with coverage	Automatically begin and end recording the FreeForm pattern when coverage logging begins and ends. <b>Note</b> – You can still use the FreeForm recording icon to manually override recording.

## Headland/Infill Switching

Use this setting to choose how guidance switches between the headland and the infill part of the field:

Select this mode ...	To ...
Automatic	Automatically switch from headland to infill when the vehicle moves inside the inner headland boundary.
Manual	Use the icons on the guidance screen to select when guidance switches from headland to infill.

## Boundary setup

Use the *Boundary Setup* option to configure:

- When boundaries are active. See [Boundaries](#), below.
- How the display records boundaries. See [Expand Boundaries](#), below.

Note the following:

- When you record a boundary, the display automatically calculates the area of the boundary and shows this information on the *Status* tab.
- When you load a field that contains a boundary, the boundary also loads.
- You can record multiple boundaries in a single field.
- If your variable rate controller has section switching capability, a boundary acts as a switching barrier. When you move outside the boundary, the controller will automatically switch off the implement.

## Boundaries

Select this mode ...	To ...
Enabled	Use existing boundaries and create new ones for all your fields.
Disabled for this field	Turn off boundaries for only the current field you are working in. When you begin your next field, the option will automatically change to Enabled.
Disabled for all fields	Turn off boundaries for all fields you work in, including boundaries made with headland patterns.

## Expand Boundaries

Use this setting to determine how the display manages the boundary after you finish recording.

If you select this mode ...	The boundary will ...
Do not expand	Not alter once you have finished recording
Half swath width	Expand by one half swath width toward the outside of the pass
One swath width	Expand by one full swath width toward the outside of the pass

## Starting Guidance

Before you can use the display for guidance, you must configure your implement:

1. From the guidance screen, tap  and then tap **Create New Field**.
2. In the *Create New Field* screen, tap **Implement Setup**.
3. Edit the settings for each option. For more information, see [Implement Setup options, page 171](#).
4. Select a pattern type (see [Guidance patterns, page 176](#)) and continue through the wizard.

## Implement Setup options

For optimum guidance, make sure that you enter accurate information for the implement that is attached to the vehicle. Incorrect information may result in gaps and overlaps in coverage.

The following table describes each of the Implement Setup options:

Option	Enter a measurement between ...	This adjusts guidance and coverage logging when ...	Notes
Implement Width	1' 00" - 328' 01" (0.305 - 99.990 m)		
Overlap/Skip	394" skip and 394" overlap (1000 cm)		To avoid skips in application coverage, set an intentional overlap.

Option	Enter a measurement between ...	This adjusts guidance and coverage logging when ...	Notes
Left/Right Offset	1969" right and 1969" left (5000 cm)	The implement is offset from the vehicle center line.	When configured and online, the implement should be over the guidance line, with the vehicle to the side.  For guidance when driving, use the LEDs on the lightbar. For more information, see <a href="#">Reading lightbar patterns, page 37</a> .
Forward/Back Offset	1188" behind and 384" forward (3018 cm - 975 cm)	The implement is not centered directly under the GPS antenna (for EZ-Steer systems) or the fixed axle of the vehicle (for Autopilot systems).	Set a Forward Offset when the implement is forward of the antenna (on the front of the vehicle) for EZ-Steer systems, or forward of the fixed axle of the vehicle for Autopilot systems.  Set a Back Offset when the implement is behind the antenna (on the back of the vehicle) for EZ-Steer systems, or behind the fixed axle of the vehicle for Autopilot systems.
Implement Draft	393.7" left and 393.7" right (1000.0 cm)	There is a variable implement draft caused by a side slope and/or an implement pulling to one side.	
Implement Mount Type			Choose the type of implement mount that is in use

## Using guidance on curved segments

After you define a guidance line, there are two ways to get guidance:

- Drive the vehicle through a tight U-turn. The next guidance line appears.
- If you are manually logging a FreeForm curve, tap  to stop defining the current line.

The FreeForm curve is similar to an adaptive curve. You must record your line on each pass to receive guidance on the next. If the vehicle is not drawing a line (or guidance trail) behind it, you are not recording your path and therefore the next guidance line will not appear.



**Note** – Do not confuse the existing guidance line with the guidance trail appearing behind the vehicle that shows your current guidance. You need to create a new guidance line to receive guidance on the next pass.

## Using guidance on straight segments

When driving on straight AB lines, you do not have to record your path because the guidance lines are generated automatically.

## Creating straight sections on Headland or Curve swaths

To create straight sections when recording headland or curve swaths:

1. Tap .
2. Drive the section.
3. Tap  to finish recording the straight section and to start recording a curve again.

## Fields

A “field” is specific area of land where events (such as planting seed or applying fertilizer) are carried out.

You create your first field when you first configure your implement (see [Starting Guidance, page 171](#)). That field remains open until you do one of the following:

- Create a new field, or load a previously saved field.
- Calibrate your EZ-Steer system.
- Perform a hard reset.

**Note** – *Fields are stored automatically. You do not have to actively save a field.*

The following sections describe how to use the field function when there is already a field currently loaded on the display.

### Creating a new field

1. In the guidance view tap . The *Finished with Field* screen appears.
2. Tap **Yes**.
3. In the *Create New or Select Old Field* screen, tap **Create New Field**.
4. To setup the new field, progress through the wizard.
5. Follow the on screen instructions to drive your new line. For more information, see [Mapping an AB line, page 177](#).

### Adding an AB line to a current field

To create a new AB line in a current field:

1. In the guidance view tap . The *Finished with Field* screen appears.
2. In the *Finished with Field* screen tap **No**.
3. In the *Create New or Select Old Swath* screen, tap **Add AB Line**.
4. To set up the new field, progress through the wizard.
5. Follow the on screen instructions to drive your new line. (For more information, see [Mapping an AB line, page 177](#)).

## Selecting (loading) an AB line into a field

1. In the guidance view tap . The *Finished with Field* screen appears.
2. In the *Finished with Field* screen tap **No**.
3. In the *Create New or Select Old Swath* screen, tap **Select Old**.
4. To set up the new field, progress through the wizard.
5. Follow the on screen instructions to drive your new line. For more information, see [Mapping an AB line, page 177](#).

## Record keeping

Optionally, you can record operational and environmental information about each field that you create, including:

- Operator
- Farm location
- Application method
- Wind direction
- Temperature
- Target pests
- EPA license number
- Vehicle
- Wind speed
- Sky conditions
- Humidity
- Applied material
- Harvest year
- Implement
- Wind gust speed
- Soil conditions
- Crop

Additionally, there are four custom fields where you can enter your own values.

To learn how to use this information, see [Chapter 11, Data](#).

## Resetting guidance

To reset guidance, in the guidance view, tap . The *Finished with Field* screen appears:



To map a new:

- **field** or select an existing field, select *Yes*.
- **AB line** or select an existing AB line in the current field, select *No*.

**Note** – If you select ‘Yes’, then the current field automatically closes. This means that you cannot cancel out of the New Field wizard and go back to your current field.

## Guidance lines

To create a guidance line, you define a start point (A) and an end point (B). Once you define the A and B points, the display draws a line between them. This is the master AB line.

**Note** – AB lines are stored automatically. You do not have to actively save an AB line.

When you define the first guidance line, the display copies it to create additional guidance lines.

## Distance between guidance lines





When you define the AB line, you specify the width of the implement that is attached to the vehicle. The display uses this measurement to calculate the distance between the guidance lines. If you do not want the guidance lines to be exactly one implement width apart, you can set an overlap or skip.

## Headlands

You can record a headland boundary, or you can work without a headland.

## On screen appearance

When the guidance screen shows the trailing view, it tags the guidance lines with the following icons:

These icon/s	Are tagged to ...
	The master line that you created. The swaths are based on this line.
 	The A (start) and B (end) point on the master line.
	<p>The first swath to the left of the master line, where 'left' is relative to the direction the master line was drawn, not the vehicle's current position.</p> <p>Note the following:</p> <ul style="list-style-type: none"> <li>• The current swath and tag are orange.</li> <li>• On a Pivot pattern, the swaths are numbered out from the center, not from the initial swath.</li> </ul>
	The second line to the left of the master line.

## Guidance patterns

Select a guidance pattern that enables you to create a guidance line to suit your field:

1. From the guidance screen, tap  and then tap **Create New Field**.
2. In the *Create New Field* screen, tap **Pattern Type**.
3. Select the pattern to use:

Pattern	To learn more, see ...
Straight AB	<a href="#">page 177</a>
A+ line	<a href="#">page 177</a>
Identical curve	<a href="#">page 178</a>
Adaptive curve	<a href="#">page 178</a>
Pivot	<a href="#">page 179</a>
Headland	<a href="#">page 179</a>
FreeForm	<a href="#">page 181</a>



## Straight AB

Use a straight AB line when you do not need to define headlands and you want to drive the field in parallel straight lines.

**Note** – When the vehicle is on a guidance line, the line extends 1 km (0.6 miles) before point A and 1 km beyond point B. This makes it easier to see where the next swath is and to get online after a turn.

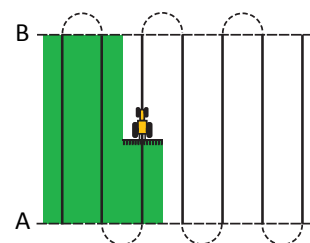

### Mapping an AB line

1. Drive to the start point of the master line.
2. Tap **A** and then drive to the end of the line.
3. When the icon is highlighted, tap **B**. The master AB line appears.
4. Turn left or right for the next swath. As you move toward the next swath, it appears on the screen and turns orange to show that it is selected.

## A+ line

An A+ line is a straight line, defined by a single A point on the line and the heading of the line. When you create an A+ line, you must enter a heading in the *A+ Heading* screen. By default, the A+ heading is the same as the previous AB line.

An A+ line is useful when you need guidance exactly parallel to the last AB line, for example when:

- driving adjacent fields
- mapping the AB line on a road down the side of the field
- skipping an access road in a field

The A+ line extends 1 km (0.6 miles) before and after the A point.

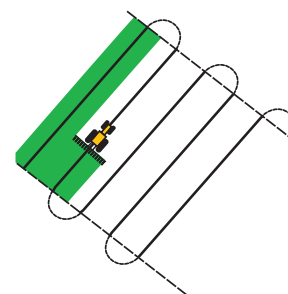

### Mapping an A+ line

1. Drive to the start point of the master line.
2. Tap **A** and then drive to the end of the line. Because you have already set the line heading, the master AB line appears on the screen.
3. For guidance down the first swath follow the AB line.
4. Turn left or right for the next swath. As you move toward the next swath, it appears on the screen and turns orange to show that it is selected.



## Identical curve

The identical curve pattern records your exact route between the A and B points, instead of creating a straight line. All subsequent guidance lines will match the master curve, regardless of where you drive the vehicle.

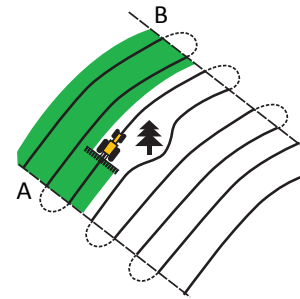
Use the identical curve pattern when you want to work a field with gentle curves.



### Mapping an identical curve

1. Drive to the start point of the curve.
2. Tap  and then drive the initial curve.
3. When the icon is highlighted, tap . The master curve appears on the screen.
4. Turn left or right for the next swath. As you move toward the next swath, it appears on the screen and turns orange to show that it is selected.

## Adaptive curve

The adaptive curve pattern provides guidance along a curve and updates guidance after each swath to take into account any deviations you make. It continually records your path and provides guidance that matches the last path you drove.

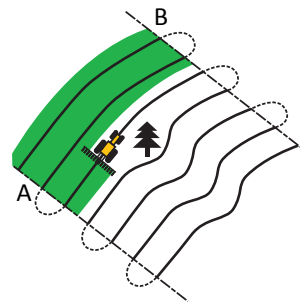

### Mapping an adaptive curve

You can map an adaptive curve either manually or automatically. The method you use depends on the Auto U-turn detection setting.



To change the Auto U-turn detection setting:

1. In the *Settings* screen, tap **Guidance**.
2. Tap **Turn Settings**, then **Auto U-Turn Detection**.
3. If you want to map the adaptive curve:
  - Automatically; select *On*.
  - Manually; select *Off*.

To map an adaptive curve with automatic turn detection:

1. Drive to the start point of the curve.
2. Tap  and then drive the initial curve.
3. At the end of the first curve, perform a U-turn. The system detects the turn and generates the next swath.

To map an adaptive curve manually:

1. Drive to the start point of the curve.
2. Tap  and then drive the initial curve.
3. At the end of the first curve, tap . The system generates the next swath.
4. Continue to drive the swaths, setting the B point at the end of each one.

### Using the adaptive curve pattern for row-finding

1. Set *Auto U-Turn Detection* to *Off*.
2. Create a guidance line based on the adaptive curve pattern.
3. Set the B point at the end of each row.
4. Turn the vehicle toward the next swath. When the vehicle is halfway through the turn, guidance along the next swath appears.

## Pivot

Use the pivot pattern on fields that use center-pivot irrigation. With this pattern, you can drive concentric circles around the center-pivot.

To map a pivot:

**Note** – Always set the master line near the outer edge of the field.

1. Drive to the start point of the pivot.
2. Position one wheel of the vehicle in a pivot wheel rut, with the rear of the vehicle to the pivot arm. If the field is not a full circle pivot, face the rear of the vehicle to the edge of the field.
3. Tap  and then drive around the field. Keep the vehicle in the rut. The display will generate guidance swaths.
4. Turn left or right for the next swath. As you move toward the next swath, it appears on the screen and turns orange to show that it is selected.
5. Steer the vehicle so that the lit LEDs are centered on the lightbar as you drive forward along the swath.

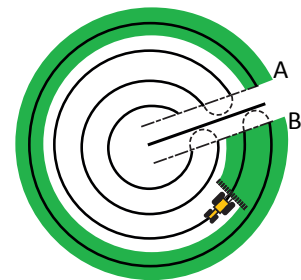

## Headland

The headland pattern enables you to define the boundary (headland) of the area, as well as the guidance lines contained within it. Use the headland pattern to allow room to turn.

The following diagrams show the two headland patterns:

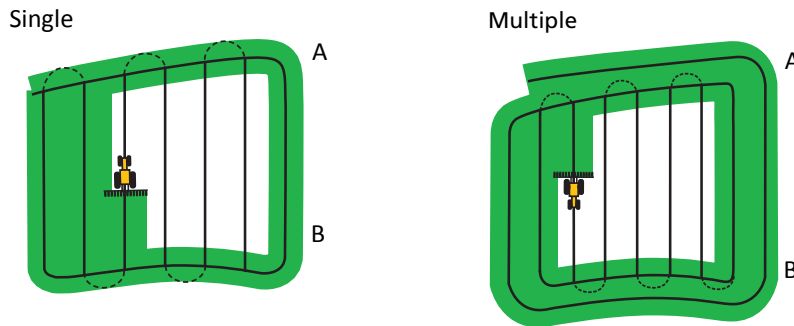

When you start to define the headland, you define the internal guidance line as you drive around the headland and then you complete the headland.

You can change two settings for the headland pattern:

- The number of circuits
- The internal pattern

### Number of circuits

When you create a headland, you must specify the total number of circuits (including the master headland). This defines how wide the headland is.

**Note** – No matter how many circuits you create, define only the outside headland. The inner headlands are copied from that original circuit.

### Internal pattern

The internal pattern is the pattern of the guidance lines inside the headland. Choose from the following:

Choose this pattern ...	To create ...
Straight AB	Standard parallel swaths inside a headland
A+	Parallel swaths at a pre-defined heading

### Reselecting the headland



When you use the headland pattern, you can see either the headland or the internal pattern.

To see the headland guidance again when you are driving the internal pattern, drive into the headland before the first internal swath or after the final internal swath. The headland appears automatically.

## Mapping a headland

1. Drive to the start point of the headland.
2. Tap  to set the start point of the headland.
3. Begin to drive the circuit of the headland.

**Note** – To ensure straight sides on the headland, you can use the pause feature. See [Creating straight sections on Headland or Curve swaths, page 173](#).

4. Tap  to set the A point of your guidance line. If the internal pattern is an:
  - A+ line, the line is set.
  - An AB Line, continue to drive around the headland. When you reach the other end of the internal guidance line, tap  to set the B point.

When you define the internal pattern guidance line, the start-point circle appears around the start point of the headland.

**Note** – If you return to the start of the headland before you define a guidance line, the headland will not complete.

5. To complete the headland, do one of the following:

**Note** – Define the master line for the internal pattern before you complete the headland.

- Drive around the rest of the headland until you return to the start-point circle. When you drive into the start-point circle, the headland completes automatically.
- Drive part of the headland and then tap . The headland completes with a straight line from the vehicle position back to the start point.

Once you complete the headland, the headland guidance line appears.

When the vehicle moves out of the headland and into the interior of the pattern, the interior is populated with your selected the guidance line pattern (straight AB or A+).

## FreeForm

Use this pattern type to create curved and straight lines for guidance in fields of any shape.



The display records the exact path you drive, and uses this to generate the next guidance line.



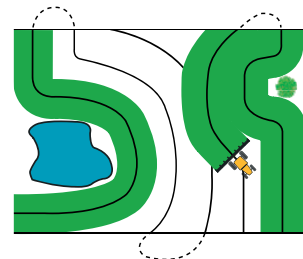

To select the FreeForm recording option:

1. In the *Settings* screen, tap **Guidance** and then **FreeForm Recording**.
2. Tap **Manual** or **Record with coverage**.





## Recording a FreeForm curve

1. Drive to the start point of the FreeForm curve.
2. To use:
  - **Manual** recording, tap .
  - **Record with Coverage** tap either  or .

While the display is recording the current path,  appears on the guidance screen.
3. Drive the curve. To record straight sections, you can use the pause feature. See [Creating straight sections on Headland or Curve swaths, page 173](#)
4. To finish recording, do one of the following:
  - If Auto U-Turn Detection is on, perform a tight U-turn.
  - For **Manual** recording, tap .
  - If you are using **Record with Coverage**, tap  or .

**Note** – If Auto U-Turn Detection option is off, you must manually stop recording at the end of each pass and then start recording again at the beginning of the next pass.

## Using the FreeForm pattern to define a straight AB line

1. Tap  and then drive to the end of the line.
2. At the end of the line, tap .

## Switching to another line

To switch from the current FreeForm guidance line to another, tap .

The first time you tap the icon, guidance snaps to the next nearest curve. Continue tapping the icon to cycle through other guidance lines.

**Note** – To use this feature, the vehicle must be within 1.5 swath widths of a FreeForm curve.

## Using FreeForm curves in spiral fields

If you are creating a spiral into the center of the field, drive the full circuit and then back onto the start of the FreeForm curve. Continue to record your guidance path as you spiral toward the center of the field.

If you encounter an obstacle in the field, continue to record your path as you drive around it. On the next pass the guidance line will adjust to reflect this.

**Note** – When you create a spiral with the FreeForm guidance pattern, there may be a space at the center of the spiral.

## Using FreeForm curves in fields with variable terrain



Start and stop recording guidance at the ends of each pass. If there are two guidance lines in close proximity, tap  to snap to the correct line.

At any point you can add a straight AB line for repeated straight line guidance.

Tap  to switch between straight AB and FreeForm curve guidance lines.

## Line Feature Guidance

Line Feature Guidance enables you to select a previously determined line feature to guide the vehicle to.

1. After setting up an AB line (see [Mapping an AB line, page 177](#)), tap  and then tap .
2. Following the on-screen instructions, begin mapping the line.
3. Map as many lines as required.

**Note** – If you have already created lines using the Farm Works software or using another display, you can load these files. Select *Settings / Data / Manage Data / USB / Retrieve Data / Get files from USB*. Ensure that the files are loaded into the same directory as the field that is currently open.

4. Tap . The *Finished with Field* screen appears:



5. Tap **No**. The *Create new or select old swath* screen appears:

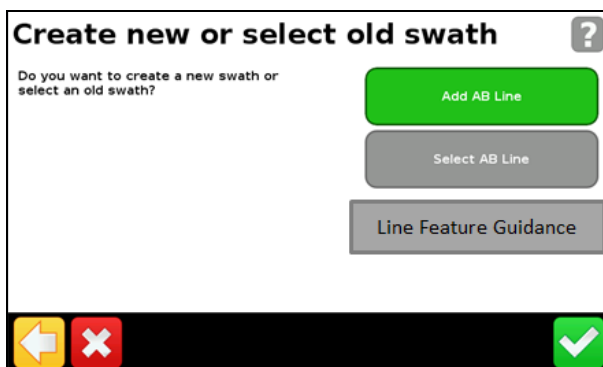

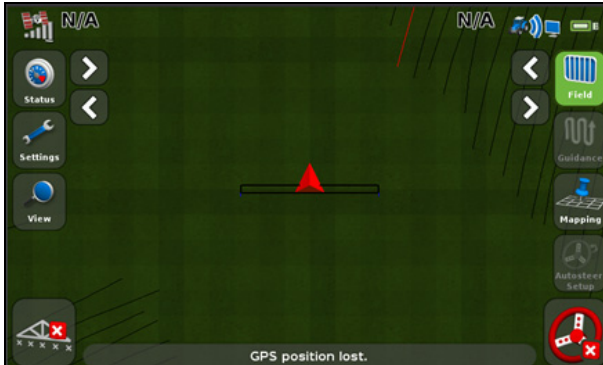

6. Tap **Line Feature Guidance**.
7. In the *Select Line Features or Swaths* screen, select the line or lines that were created/imported, or tap **Guide to All**.
8. In the *Confirm Implement* screen, confirm that the information is correct.
9. In the Run screen, the nearest selected line feature is now highlighted and can be guided to.



## Coverage logging

Coverage logging draws a solid block of color behind the vehicle to show the area that you have applied. When you pass over an area for the second time, the color of the covered area changes. This is useful for viewing overlaps.

To begin coverage logging, tap  while you are driving; to finish coverage logging tap .

**Note** – There may be a delay between the time you start or stop coverage logging onscreen and the time the implement actually starts or stops coverage. To compensate for this you can add a time delay to the drawing of coverage logging. See [Coverage on/off delay, page 168](#).

**Note** – Field coverage is limited to 1000 acres for each event.

## The pause / resume function

When you tap Pause , an icon appears on the screen to show your exact location when the guidance was paused. This enables you to return to that position in the field.

When you pause guidance:

- Your current position relative to the pause icon appears in the status bar at the top of the screen.
- The guidance line that you were on is displayed, even if you drive onto another swath.
- The pause/resume icon remembers the vehicle position even when the lightbar is turned off.



## Curve smoothing

By default, the FM-750 display smooths curves for improved guidance and auto steering. You can disable curve smoothing on tight turns (curves that have a radius of less than 3m (10 ft.).

**Note** – *If you disable curve smoothing, the FM-750 display or the Autopilot system may not be able to auto steer around the tighter turns. Be careful when you disable curve smoothing.*

To disable curve smoothing:

1. In the *Settings* screen, tap **Guidance** and then tap **Turn Settings**.
2. Tap **Minimum Turn Radius Mode** and then select **Automatic**, **Disabled** or **Manual**.

# GPS

## In this chapter:

- [Introduction](#)
- [GPS Setup](#)
- [Position Quality](#)
- [Advanced](#)
- [Status](#)

This chapter describes how to set up the GPS receiver.

## Introduction

The *GPS* menu enables you to select which GPS system and correction source to use, and the GPS quality tolerance.

To access the menu:

1. From the guidance screen, tap .
2. From the *Settings* screen, tap **GPS**:



## GPS Setup

Use the *GPS Correction Source* screen to choose the type of GPS position corrections that you want to use:

Source	Description
WAAS / EGNOS	Free satellite-based corrections: <ul style="list-style-type: none"> <li>• WAAS (Wide Area Augmentation System) in North America</li> <li>• EGNOS (European Geostationary Navigation Overlay Service) in Europe</li> </ul>
OmniSTAR VBS	Satellite-based subscription correction service
OmniSTAR XP/HP/G2	High accuracy satellite -based subscription correction service
RTK (Real Time Kinematic)	Radio-broadcast corrections from a ground-based reference station. When you select RTK as the GPS Correction Source (depending what is unlocked), any of the following may appear: Correction Delivery Method: <ul style="list-style-type: none"> <li>• Internal Radio</li> <li>• External Radio</li> <li>• CenterPoint RTX (fast-sat)</li> <li>• CenterPoint RTX (std-sat)</li> <li>• CenterPoint RTX (std-cell)</li> <li>• Trimble VRS Modem</li> <li>• Generic CMR Radio</li> <li>• Generic RTCM3 Radio</li> </ul> When any of the above RTK sources are selected, the following option appears in the <i>Advanced</i> screen: <ul style="list-style-type: none"> <li>• RTK Scintillation Mode</li> </ul>

Source	Description
RTK, <i>continued</i>	<p>If you select one of the Radio options, you can also enter:</p> <ul style="list-style-type: none"> <li>• Radio Network ID</li> <li>• SecureRTK Keys</li> <li>• SecureRTK Keys Status</li> <li>• Use xFill (select <i>Yes</i> or <i>No</i>. If you select <i>Yes</i>, the next two screens appear, <i>xFill Lband Settings</i> and <i>RTK Base Datum</i>.)</li> <li>• xFill Lband Settings (select the frequency and baud rate)</li> </ul> <p>If you select the Trimble VRS Modem or CenterPoint RTX (std-cell) option you can also select your device (DCM300 or Ag3000).</p> <p>If you select any OmniSTAR or CenterPoint RTX option, also enter:</p> <ul style="list-style-type: none"> <li>• Frequency and Baud Rate</li> <li>• FastRestart: On/Off</li> <li>• Threshold for Favor Accuracy</li> </ul> <p>• RTK Base Datum (select the datum that was used when the RTK base station was surveyed. For more information, contact your local Reseller.)</p> <p> <b>CAUTION</b> – You must select the correct base datum for your location. If you select an incorrect value, this will result in incorrect xFill operation.</p>
RangePoint™ RTX™	Satellite-based subscription correction service.
Uncorrected	No GPS corrections
Ext. Corrections	Select when using corrections from an external correction source.



## Using xFill technology

During RTK signal interruptions, xFill™ technology can sustain RTK system operation for up to 20 minutes.

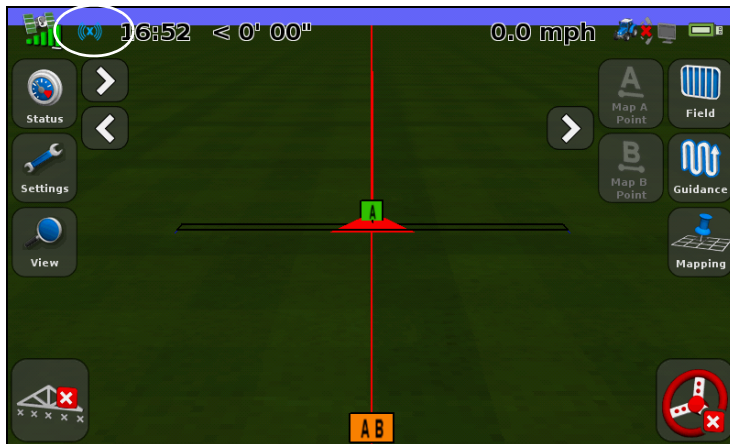
xFill technology automatically turns on when the RTK signal is interrupted. The xFill icon appears in the upper left of the Run screen:



The color of the xFill icon indicates the following:

If the icon is ...	xFill is ...
White 	ready.
Blue 	engaged, and has been used between 0 and 15 minutes.
Red 	engaged, and 5 minutes remain.

## Frequency / Baud map

The Frequency / Baud map, shown below, allows you to set the frequency and baud values based on location.

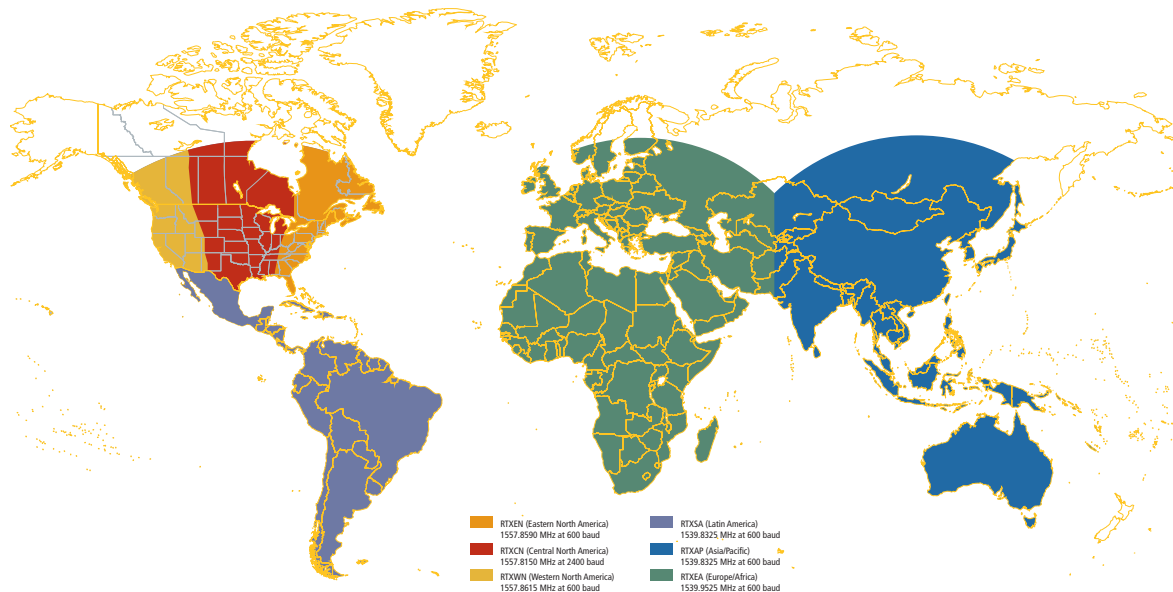

When receiving satellite signals, you must select the frequency and baud rate based on your specific region:

- Western North America (RTX WN): 1557.8615 MHz at 600 baud
- Central North America (RTX CN): 1557.8150 MHz at 2400 baud
- Eastern North America (RTX EN): 1557.8590 MHz at 600 baud
- South/Central America (RTX SA): 1539.8325 MHz at 600 baud
- Europe/Africa (RTX EA): 1539.9525 MHz at 600 baud
- Asia Pacific (RTX AP): 1539.8325 MHz at 600 baud

**Note** – These frequencies do change occasionally. If you experience issues with the satellite signal, contact your Reseller for updated satellite information.

## Position Quality

GPS signals can be disrupted by foliage, or when the machine moves out of sight of one or more satellites, or when one or more satellites move out of sight of the machine or 'set' below the horizon.

The *Position Quality* screen provides options that allow you to operate when the quality of GPS position information is compromised.

Option	Description
Favor Accuracy	Provides the highest level of accuracy.
Balanced Quality	Trades potential accuracy for a slight increase in production time.
Favor Availability	Extends production time further, with more potential for reduced accuracy.

## Advanced

The *Advanced* screen enables you to view and adjust advanced GPS settings.

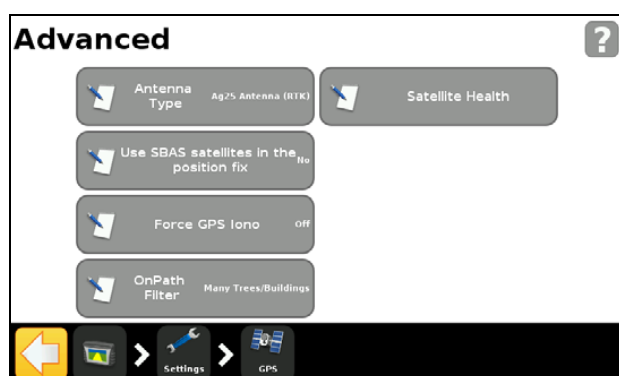

### Antenna Type

Access the *Antenna Type* screen to alter the internal settings of the GPS receiver to ensure optimum accuracy for the antenna.

Select the antenna you have connected to the display. The AG-25 antenna is white and dome shaped.

### Use SBAS satellites in the position fix

Choose this option if you want to use SBAS corrections from WAAS satellites to calculate the GPS positions. For example, if the display receives position information from six standard GPS satellites and two WAAS satellites, the display uses all eight satellites to calculate the GPS position.

This can extend operating time when limited number of satellites are available.

**Note** – This option does not work with EGNOS satellites, OmniSTAR, or RTK corrections.

### Force GPS Iono

Choose *On* to force the use of modeled rather than real-time ionosphere data.

This setting is designed primarily for locations at the edge of SBAS coverage, such as northern Canada, and could affect accuracy if used elsewhere.

## Satellite Health

You can use this setting to disregard signals from a specific satellite due to concerns about its state. For more information, contact your Reseller.

## Status

The *Status* screen enables you to view the current status of the GPS functions.

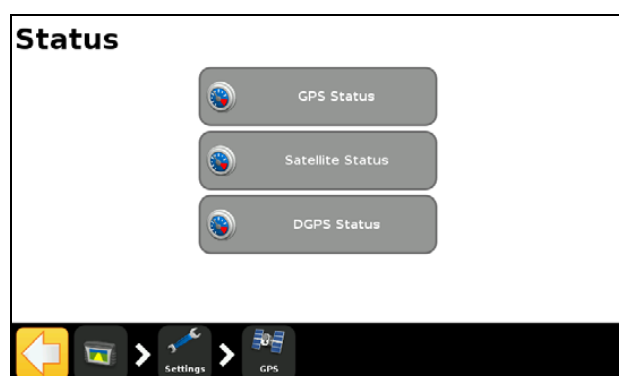

## GPS Status

The *GPS Status* screen displays information about your position and the current GPS signal strength.

## Satellite Status

The *Satellite Status* screen displays information about the current satellite constellation.

The information for each satellite is contained in one line. The following table describes fields that the line contains:

Field	Description
Sv	Satellite number <i>Note – GLONASS satellites have an "R" in front of the satellite number; GPS satellites do not.</i>
EI	Elevation
Az	Azimuth
L1	L1 SNR
L2	L2 SNR



Field	Description
Corr	Correction (appears only if correction is applied)
Used	Used (appears only if the satellite is used in position calculation)

## DGPS Status

The *DGPS Status* screen displays which DGPS signal is selected from the GPS Correction Source screen. For more information, see [GPS Setup, page 187](#).

# Data

## In this chapter:

- [Introduction](#)
- [Connected Farm Setup](#)
- [Manage Data](#)

The FM-750 display saves field data to the its internal memory. You can transfer this data to your home or office computer through a USB drive, or wirelessly through the Connected Farm™ server.

This chapter describes how to manage the data generated by the FM-750 display.

## Introduction

In the Connected Farm server, use the options in the *Data* menu to:

- Save and retrieve fields from the USB drive.
- Send fields (via Connected Farm) to your home or office computer.
- Delete fields and coverage logging.
- Export diagnostic log files to the USB drive for technical support purposes.
- Copy prescriptions from the USB drive to the internal memory and delete from the internal memory.

To access the *Data* menu:

1. From the guidance screen, tap .
2. From the *Settings* screen, select *Data*. The following screen appears:



## DCM-300 modem

This section describes how to set up a DCM-300 modem for use with VRS™ corrections.

### Passcodes

The DCM-300 modem requires a passcode **upgrade** to use VRS and Connected Farm functions.

VRS and Sync File Transfer functions in the DCM-300 modem must be **unlocked** to begin using VRS corrections or transferring data.

To unlock the modem with a passcode:

1. Turn on the modem and then connect it to the display's USB port.
2. Select the Wrench icon and then select *System / Unlock/Upgrade*.



3. Enter the passcode. When prompted, select **Yes** to restart the modem.

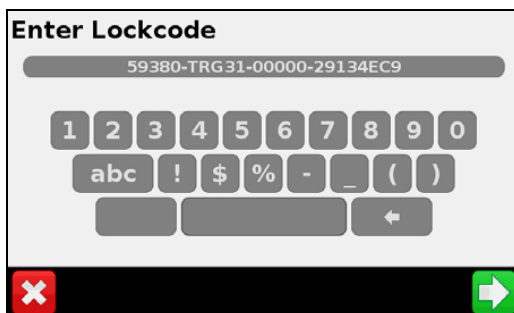

The DCM-300 modem will be ready to use after approximately three minutes.

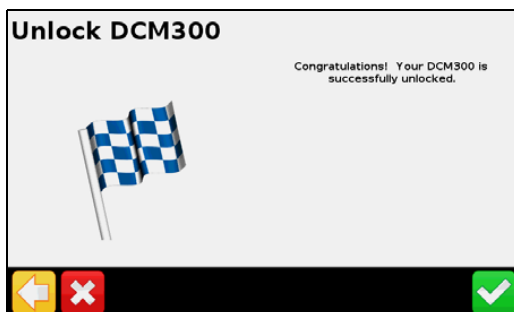

To view the status of the modem unlocks, select the Wrench icon and then select *System / Status / Upgrade Options*.

To use VRS corrections, you must unlock the File Transfer, VRS, Internet, and WiFi options.

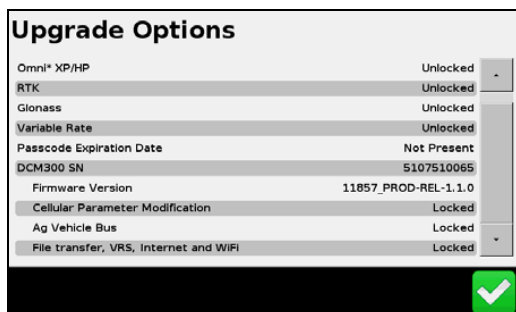

DCM-300 upgrade option	Description
Cellular Parameter Modification	Needed for DCM-300G modem when the customer supplies their own SIM card
Ag Vehicle Bus	Future functionality
File Transfer, VRS, Internet, and WiFi	Required for the use of VRS or Connected Farm Sync functions

## Configuring the display for VRS corrections

**Note** – The display must be unlocked for RTK to use the Trimble VRS correction type.

1. To access the GPS Setup screens, select the Wrench icon and then select GPS / GPS Setup / GPS Correction Source / RTK.
2. Select the option for Trimble VRS Modem and then select Continue.
3. From the device selection list, select the required Trimble modem option.

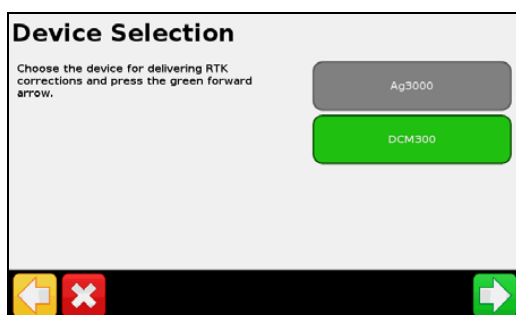
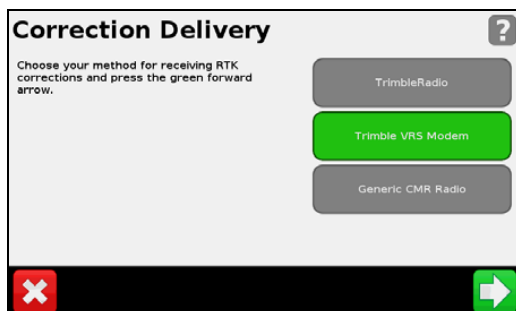

## Configuring VRS settings

1. Connect the modem and turn it on.
2. Select the required Trimble modem and then follow the on-screen instructions.

The first step in the VRS setup wizard is Wireless Modem Setup. This is required only for Trimble modems where you have installed a SIM card.

Wireless Modem settings are as follows. The SIM card provider is responsible for providing any settings required.

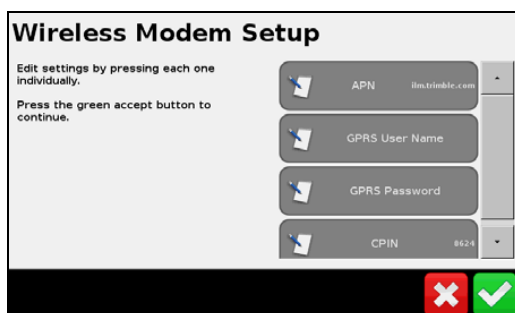

Wireless modem settings	Description
APN	Mobile Network Access Point Name, usually required by the network
GPRS User Name	Mobile Network User name, optional setting – check with your mobile network if this setting is required
GPRS Password	Mobile Network Password, optional setting – check with your mobile network if this setting is required
CPIN	SIM PIN, optional password lock to restrict use of the SIM card

The next steps in the wizard guide you through entering VRS settings provided by your Trimble CenterPoint™ or Network RTK provider. The required settings are as follows:



Internet base settings	Description
Server Name/Address	RTK/VRS/CORS base station broadcast name
Server Port Number	Server Port Number
Mount Point	Base station mount point

Internet base settings	Description
VRS User Name	Network Assigned username
VRS Password	Network Assigned password

Once the wizard is completed, a screen shows the VRS connection status, and details all the settings entered. The VRS status message types are as follows:

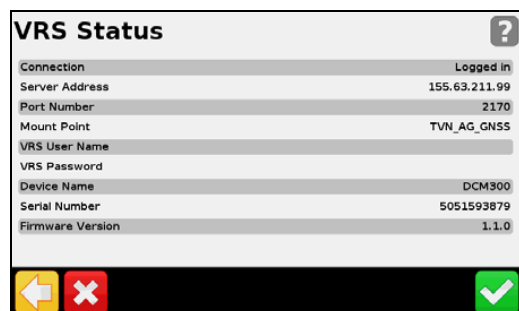

VRS connection status	Description
Logged in	VRS connected
Connecting	Mobile network - Searching
Disconnected	Mobile network - No service

## Connected Farm Setup

When you enable the Connected Farm feature, this allows the FM-750 display to use the Connected Farm server to automatically and wirelessly send field information to your home computer.

### Initial setup

The Initial Setup wizard takes you through the process of setting up your wireless modem and registering the network.

By default, the Connected Farm feature is set to *Off*. To turn the feature on:

1. Tap **Connected Farm Setup** and then **Connected Farm**.
2. Select *On*. The *Connected Farm Setup* screen appears:

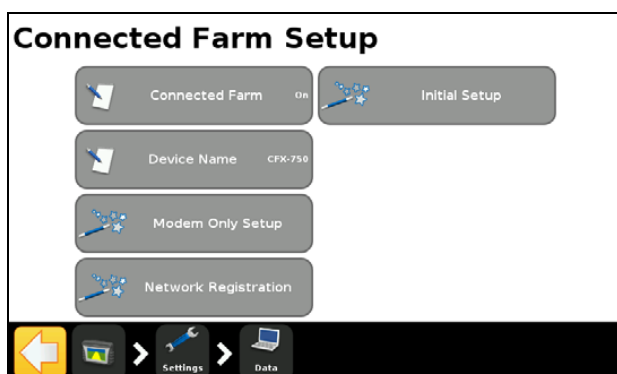

**Note** – When you turn the *Connected Farm* option *On*, tapping *Connected Farm Setup* takes you directly to the *Connected Farm Setup* screen.

The following sections describe the menu options available from the *Connected Farm Setup* screen.

## Device name

Use the on-screen keypad to give your device a name that you will recognize once you transfer the data to your personal computer.

## Modem only setup

Use this option to set up your wireless modem. Once you connect your modem, the following screen appears:

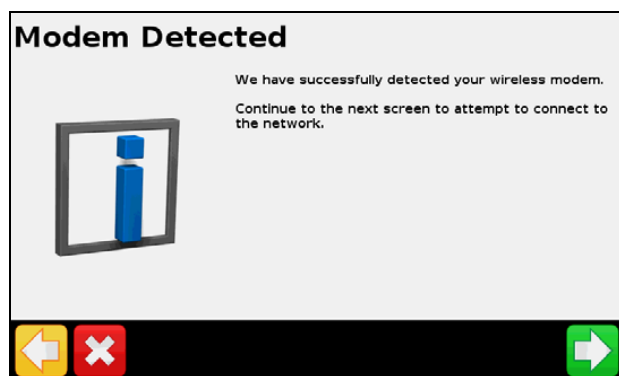

In the Wireless Modem Setup screen, you can adjust the following:

- APN/Setup String
- SIM PIN
- Network username: change the username used for network registration.
- Network password: change the password used for network registration.



After you set up your modem, the following screen appears:

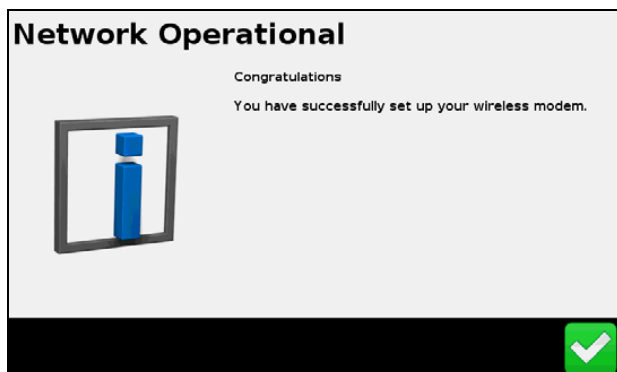

Once you receive this message, you can continue with the registration process.

**Note** – The internal settings for your modem are on the SIM card that your modem uses. For further setup information, contact your SIM card provider.

## Network registration

Register your information with the Connected Farm Network. Use the username and password you created when you purchased the Connected Farm service. For more information contact your Reseller.

## Connected Farm data transfer

**Note** – The Connected Farm service requires a subscription. For more information on purchasing a subscription, contact your Reseller.

To configure Connected Farm operations:

1. Tap  and then select *Data / Connected Farm Setup*.
2. To enable the feature, select the option to turn on the Connected Farm service.

The setup menu now includes a number of settings, as shown below. If you are a first-time user of the Connected Farm service, select Initial Setup to open a setup wizard:

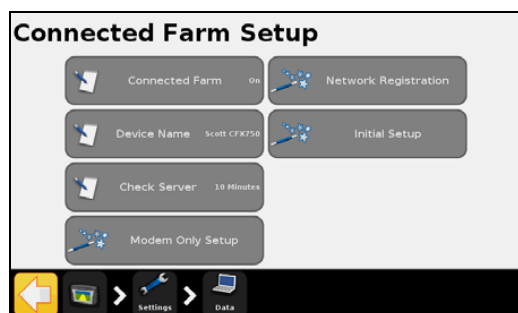

Connected Farm setup option	Description
Connected Farm	Turns Connected Farm functionality on/off
Device Name	User defined name to identify the display in Farm Works software
Check Server	Controls how often to check for new jobs or data
Modem Only Setup	Checks for a connected modem
Network Registration	Connected Farm registration
Initial Setup	First time Connected Farm setup wizard. This requires a DCM-300 modem to be connected and in an area with good wireless service. Once the initial setup is complete, you can change individual settings as required.

## Sending Field data using Connected Farm

Connected Farm field data includes event coverage, field boundaries, guidance lines, area features, line features, and point features: You can wirelessly transfer all this data from the FM-750 display to the office.

With the Connected Farm service enabled, field event data is automatically sent to the Connected Farm service when you close the event.

To manually send field events:

1. Tap  and then select *Data / Manage Data / Connected Farm / Send Data*.

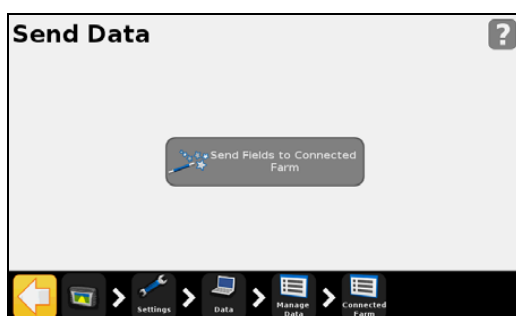

2. Use the Client, Farm, Field, and Event options to select an individual field or all events, farms, or fields for a client.

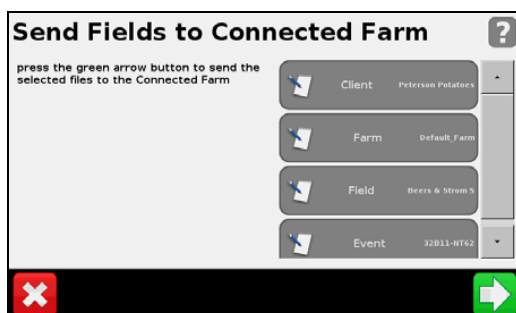

## Receiving Field data through the Connected Farm service

With the Connected Farm service, you can wirelessly transfer field information from the office to the FM-750 display. Field data includes field boundaries, guidance lines, prescriptions, area features, line features, and point features.

To receive data from the Connected Farm service:

1. Select the Wrench icon and then select *Data / Manage Data / Connected Farm / Retrieve Data*.
2. From the *Retrieve Data* screen, tap **Check Server** to check for and download new field data from the Connected Farm server.

- Once the data is downloaded, select the *Get Fields from Connected Farm* option to import the data into the display. As new data is received, use the *Get Fields from Connected Farm* function to import the most recent data into the display.

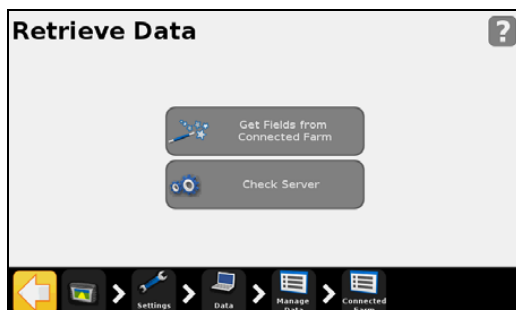

The Connected Farm service adds a status icon to the Run screen that shows the status of Connected Farm operation.

An icon at the top right of the screen shows if field data is being sent or received.

When data is being sent or received, an orange arrow blinks between the tractor and office computer.

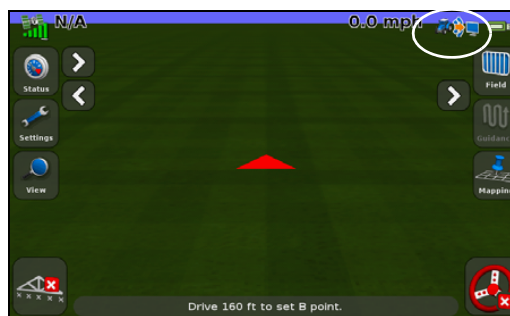
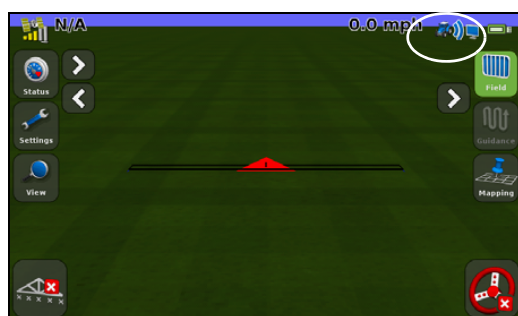

## Manage Data

The *Manage Data* screen enables you to handle your data through the USB drive or the display's internal memory.

### USB

The *USB* screen enables you to:

- Retrieve the field data and FM-750 configuration files from a USB drive and transfer it to the internal memory. The field data includes:
  - Field Boundaries
  - Point, Line and Area features
  - Guidance lines

- Event data (coverage)
- Prescriptions
- Send the following data from the internal memory to the USB drive:
  - Autopilot information
  - Prescriptions
  - Client, farm and field data

## Retrieving data from the USB drive

To transfer data from the USB drive to the internal memory:

1. In the *Manage Data* screen, tap USB.
2. Tap *Retrieve Data* and then choose the data that you would like to retrieve.

## Sending data to the USB drive

To transfer data from the internal memory to the USB drive:

1. In the *Manage Data* screen, tap USB.
2. Tap *Send Data to USB* and then select the data to send:

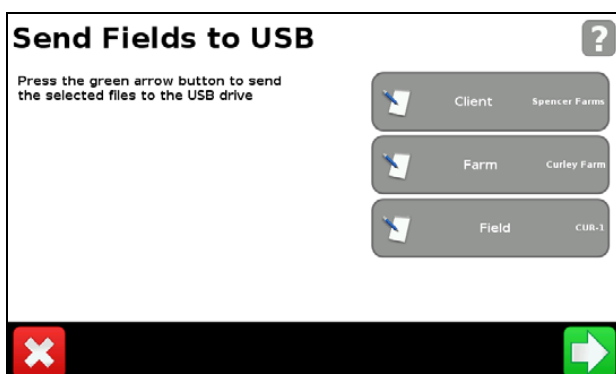

**Note** – You cannot send data to a USB drive that is over 90% full.

For more information, see [The USB socket, page 27](#).

## Clearing the internal memory

Over time, the FM-750 display's internal memory may become full. To avoid this, delete files that you no longer require:

1. In the *Manage Data* screen, tap *Internal* and then *Delete Data*.
2. Select the information to delete and then follow the wizard until the files are deleted.

**Note** – If a field is currently open it will close prior to the deletion.



# System

## In this chapter:

- [Introduction](#)
- [Display](#)
- [Advanced](#)
- [EZ-Remote joystick](#)
- [Unlock / Upgrade](#)
- [Status](#)
- [FM-750 screen](#)
- [Recalibrate touchscreen](#)

This chapter describes how to configure the system settings.

## Introduction

The *System* menu enables you to adjust a variety of the FM-750 display settings.

To access the *System* menu:

1. From the guidance screen, tap .
2. From the *Settings* screen, tap . The following screen appears:

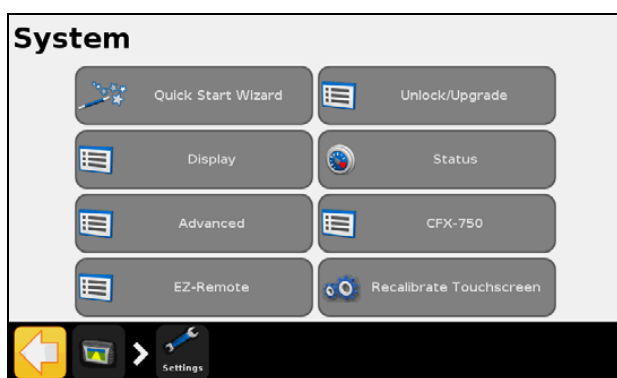

The following sections describe the various items that are available in the *System* menu.

## Display

Use the items in the *Display* screen to adjust the appearance of your FM-750 display.

## Units

You can display distances, speeds and areas in either US/Imperial or Metric format. By default, the display uses the US/Imperial format.

The available units for each format are outlined below:

Unit	US / Imperial	Metric
Distance	inches	centimeters
	feet	meters
	miles	kilometers
Speed	miles per hour	kilometers per hour
Area	acres	hectares



## Color Scheme

You can adjust your color scheme according to the cab lighting and time of day. For more information, see [Backlight](#), page 210.

This color scheme ...	Is suitable for ...
Day	A brightly lit environment.
<i>Note – This is the default color scheme.</i>	
Dimmed	Dark and low cab light environments
Red	Dark and low cab light environments

## Time Zone

The GPS receiver provides UTC (formerly GMT) time. To display and log times in your local time, set the time zone offset.

Location	Standard Time Offset	Daylight Savings Time Offset
US Eastern Time	-5:00	-4:00
US Central	-6:00	-5:00
US Mountain	-7:00	-6:00
US Pacific	-8:00	-7:00
Australia East	+10:00	-11:00 (excludes QLD)
Australia Central	+9:30	+10:30 (excludes NT)
Australia West	+8:00	+8:00

## View

There are three options for the map views:

View	Description
Auto Headland	The view automatically swaps between overhead view (in headlands) and trailing view (on swaths).
Auto Engage	The view automatically swaps between overhead view (not engaged) and trailing view (engaged).
Manual	You must manually change between overhead and trailing view.

## Status Popup Transparency

Use this option to control the transparency level of the status popup tab:

At this level of transparency ...	The tab is ...
10	completely solid
1	barely visible

## Backlight

You can adjust the brightness of the screen backlight to maximize visibility and reduce glare in different light conditions. For more information, see [Color Scheme, page 209](#).

## Touchscreen speaker volume

You can adjust the volume of the speaker according to your preference. Choose from *Loud*, *Quiet* or *Off*.

## Lightbar Setup

You can adjust the lightbar settings as follows:

Use this setting ...	To ...
Look Ahead	Allow time for large vehicles to correct offline error: <ul style="list-style-type: none"> <li>For large vehicles that take longer to turn, increase the look ahead time.</li> <li>For 4WD articulated tractors, always set the look ahead time to 0 seconds.</li> </ul> Look ahead time applies to LED guidance only and does not affect EZ-Steer performance. Set the look ahead time in seconds.
LED Spacing <b>Note</b> – The LED spacing is the distance represented by one LED.	Adjust the sensitivity of the LEDs. To: <ul style="list-style-type: none"> <li><b>increase</b> sensitivity, decrease the LED spacing</li> <li><b>decrease</b> sensitivity, increase the LED spacing</li> </ul>
LED Brightness	Adjust the LED brightness for maximum visibility.
Main Lightbar LED Mode	Select the required LED mode. There are two modes to choose from: <ul style="list-style-type: none"> <li><b>Chase</b>: Chase the lights to stay online. The lights represent the swath location relative to the vehicle.</li> <li><b>Pull</b>: Center the lights to stay online. The lights represent the vehicle location relative to the swath.</li> </ul>

## Advanced

Use the items in the *Advanced* screen to view and adjust advanced system features.

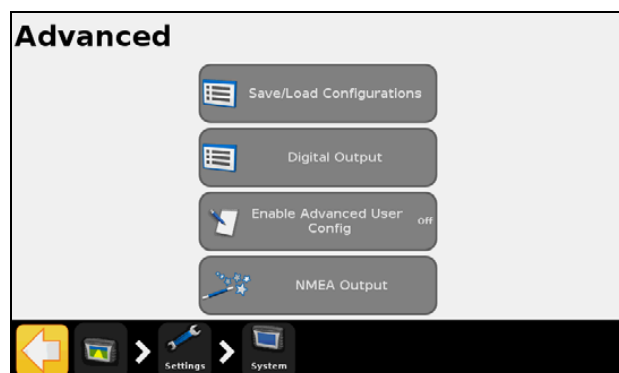

### Save/Load Configurations

Once you set up your lightbar for your current job, you can save the settings to a configuration file. Saving a system configuration can be useful for:

- Quick setup when moving the display between vehicles.
- Quick setup when using the same vehicle but changing the implement or application.
- Tuning the settings for improved performance. Save your improved settings.
- Restoring known good settings if unwanted adjustments have been made.

### Digital Output

The FM-750 display can generate a digital signal on pin 2 of Port A.

**Note** – Additional equipment may be required to properly use the Digital Output function. To use speed pulse output, you need a radar sensor cable kit that includes a pulse amplifier adapter. Contact your local Reseller.

Use this setting...	To...
Disabled	Disable digital output on pin 2 of Port A.
Radar	Output simulated radar pulses at a pre-defined speed pulse output rate. This can be useful to: <ul style="list-style-type: none"> <li>• Replace the radar/true ground speed sensor for speed on the vehicle</li> <li>• Send speed to any other agricultural device requiring speed pulses, such as a yield monitor or variable rate controller.</li> </ul> <p><b>Note</b> – After you select Radar, set the radar frequency rate from the Digital Output screen.</p>
Remote Output	Output a signal whenever auto steering is engaged. This can be useful to drive a switch or relay for equipment that should be active when engaged.

## Enable Advanced User Config



**CAUTION** – Do not use the *Enable Advanced User Config* feature unless you have the support of your Reseller. Altering any of the settings for this feature may cause system failure.

## NMEA Output

NMEA (National Marine Electronics Association) messages are a standard format that GPS devices use to communicate. The FM-750 display can output NMEA messages to communicate with other NMEA-compatible devices.

In the NMEA Port Parameters screen, specify the following:

Use this setting ...	To ...
NMEA output port	Specify the port that the NMEA device is connected to
Baud Rate	Set the transmit/receive rate of the serial port in bits per second (bps)
Data Parity	Select how the parity bit is added to the data transfer

**Note** – For the FM-750 display to communicate with another device, the Port Parameters on the display must match those of the device.

In the *Message Selection* screen, select from the list of available NMEA messages:

Message	Description
GGA	Position and fix related data
VTG	Speed and heading
GSA	Position fix mode, satellites used, and the dilution of precision (DOPs)
GLL	Position and status
RMC	Status, position, speed over ground (SOG), date, and magnetic variation of the position
ZDA	Date and time
GSV	Satellite information

## EZ-Remote joystick

The EZ-Remote option appear in the *System* menu only if you have an EZ-Remote joystick installed. For more information, see the *EZ-Remote Joystick Quick Reference Card*.

Use the *EZ-Remote* screen to:

- assign functions to buttons 1-4 on the EZ-Remote joystick
- adjust the LED brightness of the buttons

- review the button assignments.

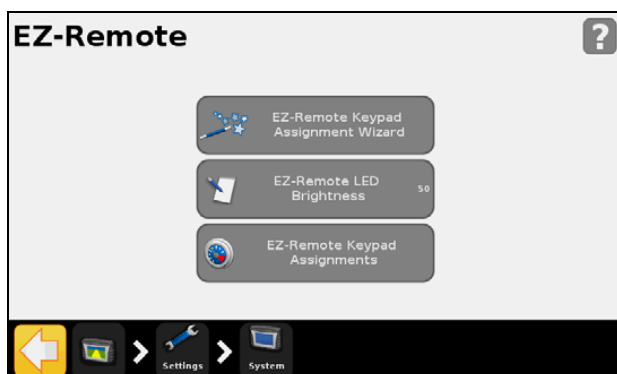

## EZ-Remote Keypad Assignment Wizard

1. On the FM-750 display, tap the first EZ-Remote joystick button to program.
2. In the *Choose a Function* screen, tap the function to assign to the joystick button. See [Using the EZ-Remote joystick, page 38](#).
3. In the *Finished* screen, select either:
  - **Choose another button** to repeat Step 1 and Step 2.
  - **Complete this wizard** to exit the wizard.

## EZ-Remote LED Brightness

Use this screen to adjust the brightness of the LED buttons on the joystick. Enter a number between 0-100.

## EZ-Remote Keypad Assignments

The *EZ-Remote Keypad Assignments* screen shows the functions that have been assigned to the four programmable buttons,

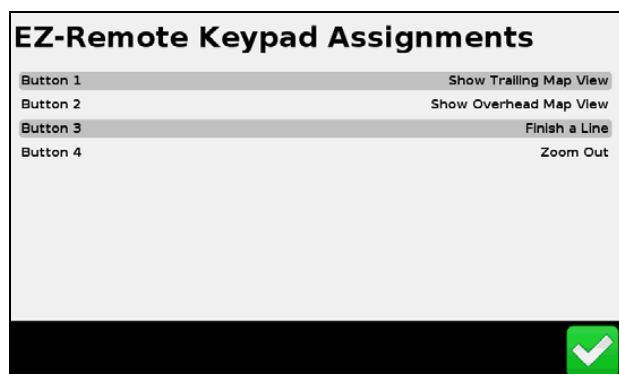

## EZ-Remote operation

When the Run screen is active on the FM-750 display, use the buttons on the EZ-Remote joystick to perform the functions you have assigned.



**Note:** The Up, Down, and Trigger buttons are not supported.

Use this button ...	To ...
Engage	Engage auto steering
Up / Down	N/A
Right	Nudge the guidance line to the <b>right</b> , in the guidance screen.
Left	Nudge the guidance line to the <b>left</b> , in the guidance screen.
Trigger	N/A
1-4	Activate the function that you have assigned. To learn how to assign a function to the programmable button, see the <a href="#">EZ-Remote joystick, page 212</a> .

## Unlock / Upgrade

Use the *Unlock/Upgrade* screen to:

- Upgrade your FM-750 display to a newer firmware version.
- Unlock features, such as the Field-IQ crop input control system.

## Upgrading your display

1. Transfer the new firmware file from [www.trimble.com](http://www.trimble.com) to your office computer.
2. Connect the FM-750 display USB memory stick to your office computer.
3. Unzip the firmware file and then save it to the root folder of the USB memory stick.
4. Insert the USB memory stick into the USB socket of the display.
5. In the Unlock/Upgrade screen, tap **Firmware Upgrade Wizard**.
6. Select the file to upload and then tap . The firmware begins to load.

Once the new firmware has successfully loaded, the display automatically restarts. **Do not** disconnect the power from the display while it is rebooting.

## Unlocking features

**Note** – To unlock features, you must obtain an unlock code from your Reseller.

1. In the Unlock/Upgrade screen, tap **Password Upgrade**.
2. Enter the unlock password. Passwords are case sensitive.

Once the password is successfully entered, the display automatically restarts. **Do not** disconnect the power from the display while it is rebooting.

## Unlocking the CenterPoint RTX correction service

1. From the guidance screen, tap .
2. From the *Settings* screen, tap **System**. The following screen appears:
3. In the *System* screen, tap **Unlock/Upgrade**:

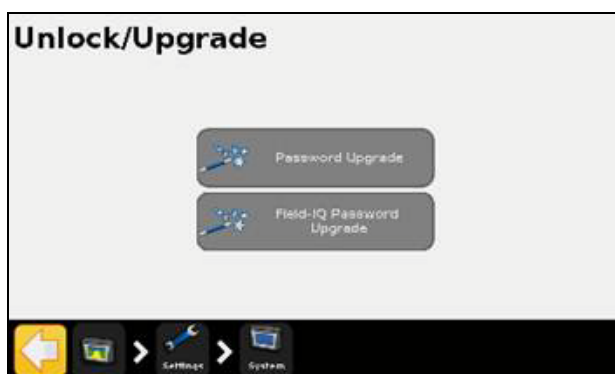

4. Tap **Password Upgrade**. The *Password Upgrade* wizard appears.

- Use the virtual keyboard to enter the password—the password is case sensitive. Ensure that you include dashes where necessary.

After you have entered a valid passcode, the Password Upgrade screen reappears with a message that the upgrade was successful. If you have entered an incorrect password, an error message appears and you are returned to the Unlock/Upgrade screen.

After you have unlocked CenterPoint RTX, set the correction type to CenterPoint RTX:

- In the *Settings* screen, tap **GPS**. The *GPS* screen appears.
- Tap **GPS Setup** and then tap **RTK**. The *GPS Correction Source* screen appears:

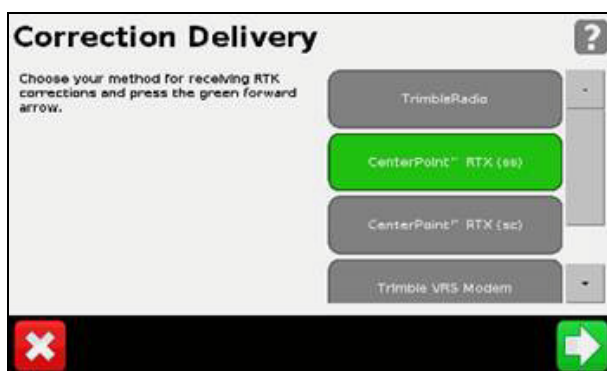

The *Correction Delivery* screen may contain the following options:

Option	Definition
CenterPoint RTX (ss)	Standard satellite
CenterPoint RTX (sc)	Standard cellular
CenterPoint RTX (fs)	Fast satellite
CenterPoint RTX (fc)	Fast cellular

- Tap **CenterPoint RTX (ss)**. The *CenterPoint RTX Setup* wizard appears. Read all cautions and warnings carefully. Select the appropriate settings:

Option	Description
Satellite Settings	There is no need to change any settings on this screen unless the CenterPoint RTX broadcast frequency has changed.
Position Quality	This screen provides options that enable you to operate when the quality of GPS position information is comprised. <ul style="list-style-type: none"> <li>Favor Accuracy - Provides the highest level of accuracy. This is the recommended setting.</li> <li>Balanced Quality - Trades potential accuracy for a slight increase in production time.</li> <li>Favor Availability - Extends production time further, with more potential for reduced accuracy.</li> </ul>



Option	Description
Threshold for CenterPoint RTX (s) Favor Accuracy	<p>Set the value at which the system will enable you to start guidance operations.</p> <ul style="list-style-type: none"> <li>• Enter a high number for broad acre applications.</li> <li>• Enter a low number for row crop applications.</li> </ul> <p><b>Note</b> – <i>The current maximum value is 11 inches.</i></p>
FastRestart	<p>FastRestart reduces the time for the position to converge so that the system is ready for operation faster.</p> <ul style="list-style-type: none"> <li>• Select <i>On</i> when the vehicle will be parked in an area with a clear view of the sky when not in use.</li> <li>• Otherwise select <i>Off</i>.</li> </ul>

- In the *Frequency* tab, the frequency and baud rate are pre-selected for the US Central beam. If necessary, these values can be changed manually to track a specific Lband satellite.
- After the wizard has been completed, return to the Run screen.

**Notes:**

- *GPS Source is CenterPoint RTX (s).*
- *Convergence is a high value.*
- *The satellite icon is yellow, indicating the system is not ready to operate.*

The status values will change while the receiver converges to its final accuracy:



**Notes:**

- *Convergence has changed to the value you set in the Threshold for CenterPoint RTX (s) Favor Accuracy screen of the wizard. In this example, the threshold was set to 11 inches.*
- *The satellite icon is now green, indicating that the system is now ready to operate.*

## Unlocking the RangePoint RTX correction service

1. From the guidance screen, tap .
2. From the *Settings* screen, tap **System**. The following screen appears:
3. In the *System* screen, tap **Unlock/Upgrade**:

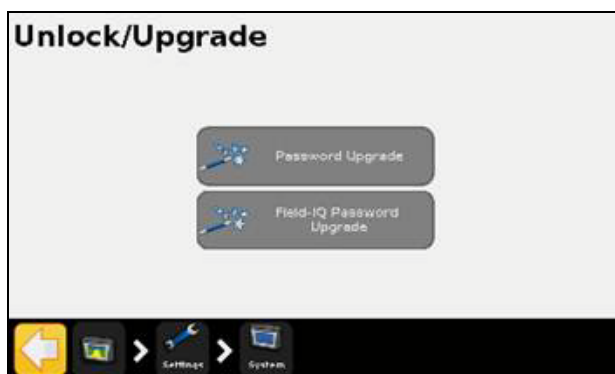

4. Tap **Password Upgrade**. The *Password Upgrade* wizard appears.
5. Use the virtual keyboard to enter the password—the password is case sensitive. Ensure that you include dashes where necessary.

After you have entered a valid passcode, the Password Upgrade screen reappears with a message that the upgrade was successful. If you have entered an incorrect password, an error message appears and you are returned to the Unlock/Upgrade screen.

After you have unlocked RangePoint RTX, set the correction type to RangePoint RTX:

1. In the *Settings* screen, tap **GPS**. The *GPS* screen appears.
2. Tap **GPS Setup** and then tap **RTK**. The *GPS Correction Source* screen appears:

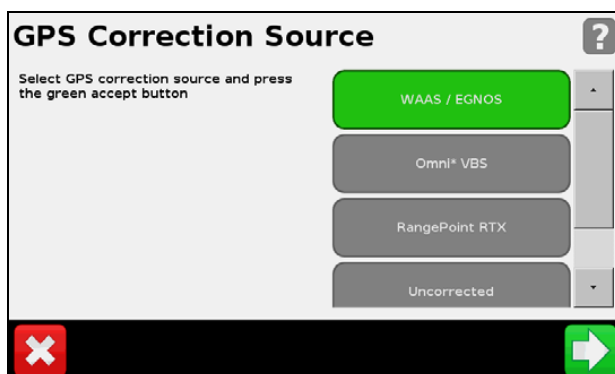

3. In the *Frequency* tab, the frequency and baud rate are pre-selected for the US Central beam. If necessary, these values can be changed manually to track a specific Lband satellite.

4. Tap **RangePoint RTX**. The *RangePoint RTX Setup* wizard appears. Read all cautions and warnings carefully. Select the appropriate settings:

Option	Description
Position Quality	<p>This screen provides options that enable you to operate when the quality of GPS position information is comprised.</p> <ul style="list-style-type: none"> <li>• Favor Accuracy - Provides the highest level of accuracy. This is the recommended setting.</li> <li>• Balanced Quality - Trades potential accuracy for a slight increase in production time.</li> <li>• Favor Availability - Extends production time further, with more potential for reduced accuracy.</li> </ul>

5. After the wizard has been completed, return to the Run screen.

**Notes:**

- *GPS Source is RangePoint RTX.*
- *Convergence is a high value.*
- *The satellite icon is yellow, indicating the system is not ready to operate.*

The status values will change while the receiver converges to its final accuracy:



**Notes:**

- *Convergence takes place in less than five minutes.*
- *The satellite icon is now green, indicating that the system is now ready to operate.*

## Status

Use the *Status* screen to view the current status of the system. The items that appear in the *Status* screen vary according to the features that you use.

Select this item ...	To view ..
Region protect	The GPS signal region you are currently in and whether it is locked or unlocked. If your region is locked, contact your Reseller.
Language Pack status	The language packs that have been installed on the display.
LB25 remote lightbar status	The following information for the lightbar: <ul style="list-style-type: none"> <li>• Status: <i>Connected</i> or <i>Disconnected</i></li> <li>• Serial number</li> <li>• Firmware version</li> </ul>
EZ-Remote status	The following information for the EZ-Remote: <ul style="list-style-type: none"> <li>• Status: <i>Connected</i> or <i>Disconnected</i></li> <li>• Serial number</li> <li>• Firmware version</li> </ul>
System status	The current time and date ID: FM-750 The following data about your FM-750 display: <ul style="list-style-type: none"> <li>• Version and Version date</li> <li>• Serial number</li> <li>• Part number</li> <li>• Hardware Revision</li> </ul> System voltage Temperature Storage: This is the number of hours of coverage logging remaining before the internal memory is full. Operational hours: This is the number of hours that the FM-750 has been operating.
Upgrade options	The status of optional features and extensions
Fault history	Those faults that have occurred recently (they may not be currently active).

## FM-750 screen

The *FM-750* screen has two options:

- **About the Display:** Shows information about your FM-750 display, including the current version and the serial number.
- **Restore Defaults:** Restores the display defaults to clear all of your current settings. If you choose to restore the default settings, the display and lightbar will restart.

## Recalibrate touchscreen

The first time you power on the display, you must calibrate the touchscreen. See [Power up, page 25](#).

If the current calibration does not read your selections accurately, use the *Recalibrate Touchscreen* option to adjust the responsiveness of the touchscreen.

Alternatively, do the following:

1. Power off the display and then power it on.
2. Wait until the status bar at the bottom of the second startup screen is more than half full:



3. Press **both** brightness control buttons at the same time:



4. Hold the two buttons down until the display beeps.